



UNIVERSITY of CALIFORNIA • IRVINE

# CHEMICAL HYGIENE PLAN



University of California, Irvine  
Environmental Health and Safety

4600 Health Sciences Road, Irvine, California 92697-2725

(949) 824-6200, Fax (949) 824-8539

# Chemical Hygiene Plan (CHP)

## Chapters

Chapter 1: Introduction.....	1-1
Chapter 2: Chemical Hazard Communication .....	2-1
Chapter 3: Classes of Hazardous Chemicals.....	3-1
Chapter 4: How to Reduce Exposures to Hazardous Chemicals.....	4-1
Chapter 5: Chemical Exposure Assessment.....	5-1
Chapter 6: Inventory, Labeling, Storage and Transport.....	6-1
Chapter 7: Training .....	7-1
Chapter 8: Inspections and Compliance .....	8-1
Chapter 9: Hazardous Waste Management .....	9-1
Chapter 10: Accidents, Emergencies, and Chemical Spills.....	10-1

## Appendices

Appendix A: General Rules for Laboratory Work with Chemicals .....	A-1
Appendix B: Container Labelling.....	B-1
Appendix C: Standard Operating Procedures Instructions and Template.....	C-1
Appendix D: Safe Use of Particularly Hazardous Substances .....	D-1
Appendix E: Respiratory Hazard Assessment Form .....	E-1
Appendix F: Peroxide Forming Chemicals .....	F-1
Appendix G: Safe Use of Pyrophoric Reagents.....	G-1
Appendix H: Segregation of Incompatible Chemicals .....	H-1
Appendix I: Spill Clean-Up Procedures.....	I-1
Appendix J: Glossary.....	J-1

# Chapter 1: Introduction

## Purpose

The University of California, Irvine (UCI) is committed to providing a healthy and safe working environment for the campus community, free from recognized hazards in accordance with UC Policy (<https://www.ucop.edu/research-policy-analysis-coordination/resources-tools/contract-and-grant-manual/chapter3/chapter-3-200.html>) and UCI Policy (<http://www.policies.uci.edu/policies/pols/903-10.php>). The Chemical Hygiene Plan (CHP) establishes a formal written program for protecting laboratory personnel against adverse health and safety hazards associated with exposure to potentially hazardous chemicals and must be made available to all employees working with hazardous chemicals. The CHP describes the proper use and handling practices and procedures to be followed by faculty, staff, students, visiting scholars, and all other personnel working with potentially hazardous chemicals in laboratory settings at UCI. This plan is based on best practices identified in, among others sources, “Prudent Practices for Handling Hazardous Chemicals in Laboratories,” published by the National Research Council, and the American Chemical Society’s “Safety in Academic Chemistry Laboratories” ([www.acs.org/SACL](http://www.acs.org/SACL)).

## Scope

The CHP applies to all laboratories that use, store, or handle potentially hazardous chemicals and all personnel who work in these facilities. It does not apply to research involving exclusively radiological or biological materials, as these safety procedures and regulatory requirements are outlined in the Radiation Safety Manual (<http://www.ehs.uci.edu/programs/radiation/RadiationSafetyManual.pdf>) and Biosafety Manual (<http://www.ehs.uci.edu/programs/biosafety/BiosafetyManual.pdf>), respectively. Research involving more than one type of hazard must comply with all applicable regulatory requirements and follow guidance outlined in the relevant safety manuals. Additional oversight may be necessary depending on the work being conducted.

The information presented in the CHP is not intended to be all-inclusive. Departments, divisions or other work units engaged in work with potentially hazardous chemicals that have unusual characteristics, or are otherwise not sufficiently covered in the written CHP, must customize the document by adding additional sections addressing the hazards and how to mitigate their risks, as appropriate. Such customizations must receive prior approval from the PI/Laboratory Supervisor and/or the Office of Environmental, Health and Safety (EH&S). See *Appendix D: Safe Use of Particularly Hazardous Substances* for additional information on substances that may trigger these additions. For information on specific chemical safety topics not covered in the CHP, please contact EH&S, 4-6200.

## Regulatory Requirements

Implementation of the necessary work practices, procedures, and policies outlined in this CHP is required by the following:

- *Title 8, California Code of Regulations (CCR), Section 5191, “Occupational Exposures to Hazardous Chemicals in Laboratories”* (<http://www.dir.ca.gov/title8/5191.html>)

- Title 8, CCR, Article 110, Sections 5200-5220 regulated carcinogens including, but not limited to:
  - Section 5203 “Carcinogen Report of Use Requirements” (<http://www.dir.ca.gov/title8/5203.html>),
  - Section 5209, “Carcinogens” (<http://www.dir.ca.gov/title8/5209.html>)
- Title 8, CCR, Section 5154.1, “Ventilation Requirements for Laboratory-Type Hood Operations” ([http://www.dir.ca.gov/title8/5154\\_1.html](http://www.dir.ca.gov/title8/5154_1.html))

Other applicable regulations include those promulgated by the U.S. Department of Labor including 29 CFR 1910.1450 "Occupational Exposure to Hazardous Chemicals in Laboratories" (the "Laboratory Standard"). EH&S will review and evaluate the effectiveness of this Plan at least annually and update it as necessary.

The University of California has enacted UC-wide policies pertaining to minors in the laboratories and shops (<https://policy.ucop.edu/doc/3500602/MinorsLabsShops>) and laboratory safety training (<https://policy.ucop.edu/doc/3500598/LabSafetyTraining>).

## Rights and Responsibilities

Employees and other personnel who work in or enter laboratories have the right to be informed about the potential health hazards of the chemicals in their work areas and to be properly trained to work safely with or in proximity to these substances. Employees have the right to file a complaint with Cal/OSHA if they feel they are being exposed to unsafe or unhealthy work conditions and cannot be discharged, suspended, or otherwise disciplined by their employer for filing a complaint or exercising these rights. *All personnel working with potentially hazardous chemicals are encouraged to report (anonymously, if preferred) any concerns about unsafe work conditions to **EH&S** at <https://www.ehs.uci.edu/apps/hr/index.jsp> or 949-824-6200.*

Responsibilities for the health and safety of the campus community extend to the highest administrative levels of UCI. The Chancellor and Vice Chancellors are responsible for the implementation of the UC’s Environmental Health and Safety Policy (<https://www.ucop.edu/research-policy-analysis-coordination/resources-tools/contract-and-grant-manual/chapter3/chapter-3-200.html>) at all facilities and properties under campus control. Deans and Department Heads are responsible for establishing and maintaining programs in their areas and for providing a safe and healthy work environment. (<http://www.policies.uci.edu/policies/pols/903-10.php>)

The day-to-day responsibility for the management of laboratory safety and adherence to safe laboratory practices rests with the PI/Laboratory Supervisor within individual laboratory units and associated departments. All personnel, including PIs/Laboratory Supervisors, employees, and students, have a duty to fulfill their obligations with respect to maintaining a safe work environment. Safety is everyone’s responsibility and should be everyone’s priority.

The students and employees who work with hazardous substances have the primary responsibility for safety in the lab. Students and employees shall follow all of the safety guidelines and report any unsafe conditions. All employees and other personnel working with potentially hazardous chemicals have the responsibility to conscientiously participate in training seminars on general laboratory safety and review and be familiar with the contents of the CHP. Those working with chemicals are responsible for staying informed about the chemicals in their work areas, safe work practices and proper personal protective equipment (PPE) required for the safe performance of their job. Failure to comply with these

requirements will result in progressive disciplinary action in accordance with UC policy, and may result in temporary suspension of laboratory activities until corrective action is implemented.

Specific duties and responsibilities of personnel who work in areas where potentially hazardous chemicals are present have been compiled in the document entitled General Rules for Laboratory Work with Chemicals, found in Appendix A. These general rules provide guidelines for working with hazardous materials, each laboratory must develop and follow standard operating procedures (SOPs) which outline the laboratory specific practices and procedures when using hazardous chemicals. Each member of the laboratory should have access to these documents and should review them before conducting work in the laboratory.

## **RESPONSIBILITIES OF PRINCIPAL INVESTIGATOR (PI)/ LABORATORY SUPERVISOR**

The PI/Laboratory Supervisor has responsibility for the health and safety of all personnel working in their laboratory who handle hazardous chemicals. The PI/Laboratory Supervisor may delegate safety duties, but remains responsible for ensuring that delegated safety duties are adequately performed. The PI/Laboratory Supervisor has the primary responsibility for establishing a strong safety culture within the laboratory they supervise. The PI/Laboratory Supervisor is responsible for:

1. Knowing all applicable health and safety rules and regulations, training and reporting requirements and standard operating procedures associated with chemical safety for regulated substances;
2. Identifying hazardous conditions or operations in the laboratory or other facility containing hazardous chemicals and determining safe procedures and controls, and implementing and enforcing standard safety procedures;
3. Establishing standard operating procedures (general and protocol specific) and performing literature searches relevant to health and safety for laboratory-specific work;
4. Providing prior-approval for the use of hazardous chemicals in their laboratory or other facility with hazardous chemicals;
5. Consulting with EH&S and/or Departmental Safety Committee on use of higher risk materials, such as use of particularly hazardous substances, as defined by UCI Guidelines, or conducting higher risk experimental procedures so that special safety precautions are taken;
6. Maintaining an up-to-date and accurate chemical inventory (this includes all hazardous materials and compressed gases) for the laboratory or facility;
7. Ensuring laboratory or other personnel under their supervision have access to and are familiar with the appropriate Safety Manual(s);
8. Training all laboratory or other personnel they supervise to work safely with hazardous materials and maintain written records of all training (including laboratory-specific or other specialized training) in the Safety Manual;
9. Promptly notifying EH&S and/or Facilities Management should they become aware that work place engineering controls (e.g., fume hoods) and safety equipment (e.g., emergency showers/eyewashes, fire extinguishers, etc.) become non-operational;
10. Ensuring the availability of all appropriate personal protective equipment (PPE) (e.g., laboratory coats, gloves, eye protection, etc.) and ensuring the PPE is maintained in working order. Ensuring that all employees wear the appropriate PPE when working with or adjacent to hazard chemicals, and wearing the appropriate PPE every time they enter the laboratory;
11. Conducting periodic self-inspections of laboratory or facility and maintaining records of inspections, as required;

12. Promptly reporting of accidents and injuries to EH&S. Serious injuries MUST be reported to EH&S immediately to allow for compliance within the CAL/OSHA **8-hour** reporting time frame. Any doubt as to whether an injury is serious should favor reporting;
  - a. All explosions, unintended fires, or uses of a fire extinguisher must be reported to EH&S. It is imperative that a used fire extinguisher is given to EH&S to be refilled.
13. Providing funding for medical surveillance and/or medical consultation and examination for laboratory and other personnel, as required;
14. Informing facilities personnel, other non-laboratory personnel and any outside contractors of potential laboratory-related hazards when they are required to work in the laboratory environment;
15. Identifying and minimizing potential hazards to provide a safe environment for repairs and renovations.

## **RESPONSIBILITIES OF ALL PERSONNEL WHO HANDLE POTENTIALLY HAZARDOUS CHEMICALS**

All personnel in research or teaching laboratories that use, handle or store potentially hazardous chemicals are responsible for:

1. Reviewing and following the requirements of the CHP and all appropriate Safety Manuals and Policies;
2. Following all verbal and written laboratory safety rules, regulations, and standard operating procedures required for the tasks assigned;
3. Developing good personal chemical hygiene habits, including but not limited to, keeping the work areas safe and uncluttered;
4. Planning, reviewing, and understanding the hazards of materials and processes in their laboratory research or other work procedures prior to conducting work;
5. Properly identifying/labeling, storing, handling, and disposing of hazardous waste;
6. Utilizing appropriate measures to control identified hazards, including consistent and proper use of engineering controls, personal protective equipment, and administrative controls;
7. Understanding the capabilities and limitations of PPE issued to them;
8. Gaining prior approval from the PI/Laboratory Supervisor for the use of restricted chemicals and other materials;
9. Consulting with PI/Laboratory Supervisor before using any particularly hazardous substances (PHS), pyrophoric chemicals, explosives and other highly hazardous materials or conducting certain higher risk experimental procedures;
10. Immediately reporting all accidents, unsafe conditions, and near-misses to the PI/Laboratory Supervisor and EH&S;
11. Completing all required health, safety and environmental training and providing written documentation to their PI/Laboratory Supervisor;
12. Participating in the medical surveillance program, when required;
13. Informing the PI/Laboratory Supervisor of any work modifications ordered by a physician as a result of medical surveillance, occupational injury or exposure;
14. When working autonomously or performing independent research or work:
  - a. Reviewing the plan or scope of work for their proposed research with the PI/Laboratory Supervisor
  - b. Notifying in writing and consulting with the PI/Laboratory Supervisor, in advance, if they intend to significantly deviate from previously reviewed procedures (Note: Significant change may include, but is not limited to, change in the objectives, change in PI, change

- in the duration, quantity, frequency, conditions or location, increase or change in PPE, and reduction or elimination of engineering controls.)
- c. Preparing SOPs and performing literature searches relevant to safety and health that are appropriate for their work;
  - d. Providing appropriate oversight, training and safety information to laboratory or other personnel they supervise or direct.

## **RESPONSIBILITIES OF EH&S AND CHEMICAL HYGIENE OFFICER (CHO)**

EH&S is responsible for administering and overseeing institutional implementation of the Laboratory Safety Program. The campus Chemical Hygiene Officer (CHO), (949) 824-8342, is designated by EH&S, and is qualified by training and experience, to provide technical guidance in the development and implementation of the provisions of the Chemical Hygiene Plan. In case of life safety matters or imminent danger to life or health, the Director of EH&S or designee has the authority to order the cessation of the activity until the hazardous condition is abated. EH&S provides technical guidance to personnel at all levels of responsibility on matters pertaining to laboratory use of hazardous materials. The CHO is a member of EH&S and, with support from other EH&S personnel, is responsible for:

1. Informing PIs/Laboratory Supervisors of all health and safety requirements and assisting with the selection of appropriate safety controls, including laboratory and other workplace practices, personal protective equipment, engineering controls, training, etc.;
2. Conducting periodic inspections and immediately taking steps to abate hazards that may pose a risk to life or safety upon discovery of such hazards;
3. Performing hazard assessments, upon request;
4. Helping to develop and implement appropriate chemical hygiene policies and practices;
5. Having working knowledge of current health and safety rules and regulations, training, reporting requirements and standard operating procedures associated with regulated substances. Such knowledge may be supplemented and developed through research and training materials;
6. Working with research staff to review existing SOPs and assist with developing new SOPs for handling hazardous chemicals;
7. Providing technical guidance and investigation, as appropriate, for laboratory and other types of accidents and injuries;
8. Helping to determine medical surveillance requirements for potentially exposed personnel;
9. Reviewing plans for installation of engineering controls and new facility construction/renovation, as requested;
10. Reviewing and evaluating the effectiveness of the CHP at least annually and updating it as appropriate

## Chapter 2: Chemical Hazard Communication

### Regulatory Requirements

UCI is responsible for providing information about the hazardous substances in our workplace, the associated hazards, and the control of these hazards, through a comprehensive hazard communication program that is summarized briefly below. UCI has an established Hazard Communication Program that complies with Title 8 CCR 5194 (<http://www.dir.ca.gov/title8/5194.html>), the Cal/OSHA Hazard Communication Standard. In line with Cal/OSHA HAZCOM, the purpose of UCI's Hazard Communication Program is to ensure that all employees and, upon request, their personal physicians, have the right to receive information regarding the hazardous substances to which they may have been exposed at work. The requirements of the Hazard Communication Program apply to laboratory environments at UCI due to the potential for large-scale experiments and for activities that may occur outside of areas where engineering controls are available. Proper hazard communication involves the active participation of the PI/Laboratory Supervisor, the EH&S Chemical Hygiene Officer, and the Laboratory/Facility Safety Coordinator, who are each responsible for providing consultation and safety information to employees working with hazardous chemicals.

### List of Hazardous Substances

Every lab group is required to keep an updated copy of their chemical inventory on file, which must be made available to EH&S upon request. For each hazardous substance on their inventory, specific information on any associated health or safety hazards must be made readily available to all laboratory personnel. Compressed gases need to be included in the chemical inventory.

### Hazard Determination

PIs/Laboratory Supervisors are responsible for verifying if any items on their chemical inventory are subject to the requirements of the hazard communication regulation.

The term "hazardous substance" refers to any chemical for which there is statistically significant evidence based on at least one study conducted in accordance with established scientific principles that acute or chronic health effects may occur in exposed individuals. Hazardous substances include, but are not limited to, those chemicals listed in the following:

1. "The Hazardous Substance List", commonly known as the Directors List of Hazardous Substances, 8 CCR 339 (<http://www.dir.ca.gov/title8/339.html>);
2. "Toxic and Hazardous Substances, Air Contaminants", 8 CCR, Section 5155 (<http://www.dir.ca.gov/title8/5155.html>);
3. "Threshold Limit Values for Chemical Substances in the Work Environment", ACGIH, 2012;
4. "Fourteenth Annual Report on Carcinogens", NTP, 2016 ([https://ntp.niehs.nih.gov/ntp/roc/content/listed\\_substances\\_508.pdf](https://ntp.niehs.nih.gov/ntp/roc/content/listed_substances_508.pdf); <https://ntp.niehs.nih.gov/pubhealth/roc/index-1.html>);
5. "Monographs", IARC, WHO (<https://monographs.iarc.fr/agents-classified-by-the-iarc/> and [https://monographs.iarc.fr/wp-content/uploads/2019/07/Classifications\\_by\\_cancer\\_site.pdf](https://monographs.iarc.fr/wp-content/uploads/2019/07/Classifications_by_cancer_site.pdf));
6. SDSs for reproductive toxins and cancer causing substances (<http://www.ehs.uci.edu/msds.html>); and



7. "Chemicals Known to the State to Cause Cancer or Reproductive Toxicity" (Proposition 65), 22 CCR 12000 (<https://oehha.ca.gov/proposition-65/proposition-65-list>).

Any novel chemical produced should be presumed hazardous. Chemicals derivatives of known materials should be assumed at least as hazardous as their known parent compound. Novel compounds should be treated with extreme caution to prevent exposure.

Inventory items found on the above lists are subject to the requirements outlined below.

## **SAFETY DATA SHEETS (SDS)**

A Safety Data Sheet (SDS), formerly known as a material safety data sheet, MSDS, must be available for each hazardous substance in a laboratory's chemical inventory. SDSs are available from the UC online SDS library, available on the UC website: (<http://www.ehs.uci.edu/msds.html>), UC Chemicals, the new inventory system, has an attached SDS for most chemical entries. PIs/Laboratory Supervisors are responsible for keeping SDSs current and making them available to all laboratory employees throughout the workday. SDSs must be in a central location that can be accessed immediately in the event of an emergency. Electronic copies may be kept in a file on a group drive, or hard copies maintained in a central location in the laboratory.

New chemical substances synthesized or produced in a laboratory, and used or shared outside of a laboratory suite, require the preparation of an SDS for each synthesized substance. The UC-system wide SDS library has the capability of developing new SDSs based on the known chemical and physical properties of that substance. Contact EH&S, 4-6200 for more information on preparing new SDSs.

New Global Harmonization System (GHS) requires the standardization of SDSs. The minimum information required for an SDS is:

### **1. Identification of the substance or mixture and of the supplier**

- GHS product identifier.
- Other means of identification.
- Recommended use of the chemical and restrictions on use.
- Supplier's details (including name, address, phone number, etc.).
- Emergency phone number.

### **2. Hazards identification**

- GHS classification of the substance/mixture and any national or regional information.
- GHS label elements, including precautionary statements. (Hazard symbols may be provided as a graphical reproduction of the symbols in black and white or the name of the symbol, e.g., flame, skull and crossbones.). Symbols are required to be in a diamond with a red border.
- Other hazards which do not result in classification (e.g., dust explosion hazard) or are not covered by the GHS.

### **3. Composition/information on ingredients**

#### **a. Substance**

- Chemical identity.
- Common name, synonyms, etc.
- CAS number, EC number, etc.
- Impurities and stabilizing additives which are themselves classified and which contribute to the classification of the substance.

#### **b. Mixture**

- The chemical identity and concentration or concentration ranges of all ingredients which are hazardous within the meaning of the GHS and are present at or above their cutoff levels.
- 4. First aid measures**
    - Description of necessary measures, subdivided according to the different routes of exposure, e.g., inhalation, skin and eye contact, and ingestion.
    - Most important symptoms/effects, acute and delayed.
    - Indication of immediate medical attention and special treatment needed, if necessary.
  - 5. Firefighting measures**
    - Suitable (and unsuitable) extinguishing media.
    - Specific hazards arising from the chemical (e.g., nature of any hazardous combustion products).
    - Special protective equipment and precautions for firefighters.
  - 6. Accidental release measures**
    - Personal precautions, protective equipment and emergency procedures.
    - Environmental precautions.
    - Methods and materials for containment and cleaning up.
  - 7. Handling and storage**
    - Precautions for safe handling.
    - Conditions for safe storage, including any incompatibilities.
  - 8. Exposure controls/personal protection.**
    - Control parameters (e.g., occupational exposure limit values or biological limit values).
    - Appropriate engineering controls.
    - Individual protection measures, such as personal protective equipment.
  - 9. Physical and chemical properties**
    - Appearance (physical state, color, etc.).
    - Odor.
    - Odor threshold.
    - pH.
    - Melting point/freezing point.
    - Initial boiling point and boiling range.
    - Flash point.
    - Evaporation rate.
    - Flammability (solid, gas).
    - Upper/lower flammability or explosive limits.
    - Vapor pressure.
    - Vapor density.
    - Relative density.
    - Solubility(ies).
    - Partition coefficient: n-octanol/water.
    - Auto-ignition temperature.
    - Decomposition temperature.
  - 10. Stability and reactivity**
    - Chemical stability.
    - Possibility of hazardous reactions.
    - Conditions to avoid (e.g., static discharge, shock or vibration).
    - Incompatible materials.
    - Hazardous decomposition products.
  - 11. Toxicological information**

- Concise but complete and comprehensible description of the various toxicological (health) effects and the available data used to identify those effects, including:
- Information on the likely routes of exposure (inhalation, ingestion, skin and eye contact);
- Symptoms related to the physical, chemical and toxicological characteristics;
- Delayed and immediate effects and also chronic effects from short- and long-term exposure;
- Numerical measures of toxicity (such as acute toxicity estimates).

#### **12. Ecological information**

- Eco-toxicity (aquatic and terrestrial, where available).
- Persistence and degradability.
- Bio-accumulative potential.
- Mobility in soil.
- Other adverse effects.

#### **13. Disposal considerations**

- Description of waste residues and information on their safe handling and methods of disposal, including the disposal of any contaminated packaging.

#### **14. Transport information**

- UN Number.
- UN Proper shipping name.
- Transport Hazard class(es).
- Packing group, if applicable.
- Marine pollutant (Yes/No).
- Special precautions which a user needs to be aware of or needs to comply with in connection with transport or conveyance either within or outside their premises.

#### **15. Regulatory information**

- Safety, health and environmental regulations specific for the product in question.

#### **16. Other information including information on preparation and revision of the SDS**

## **LABELS AND OTHER FORMS OF WARNING**









Every chemical in the laboratory (including nonhazardous materials, e.g. water) must be labeled properly. Labeling requirements for all hazardous substances are summarized as follows:

- All containers of purchased hazardous materials or materials intended for distribution must be labeled with the identity of the hazardous substance
- The label must contain all applicable hazard warning statements
- The name and address of the chemical manufacturer, generator, or other responsible party must be present
- Manufacturer's product labels must remain on all containers, and must not be defaced in any way. Appropriate hazard warning statements and Proposition 65 warnings must be present, if not that information must be added
  - If a container is going to be reused ensure that all the material has been removed (you should not be able to pour or scrap any material from the container), then soak the label off before reusing the container. Never put a new label over an old label.
- Labels must be legible, in English, and prominently displayed
- Symbols and/or other languages are required for non-English speaking employees

- Working containers (such as spray bottles) must be labeled with the identity of the substance and appropriate hazard warnings
- Prepared mixtures and/or buffers must be labeled with the appropriate hazard warnings based on the knowledge of the chemical and physical properties of that substance.
- New synthesized compounds must be labeled with the employee's information and the chemical name or structure if known or at a minimum a chemical identification number derived from the employee's lab-book.
- Global Harmonization System symbols should be used when labeling containers.

Additional information on container labeling is provided in *Appendix B*.

## GLOBAL HARMONIZATION SYSTEM (HAZARD COMMUNICATION STANDARD PICTOGRAMS)

<p style="text-align: center;"><b>Health Hazard</b></p>  <ul style="list-style-type: none"> <li>• Carcinogen</li> <li>• Mutagenicity</li> <li>• Reproductive Toxicity</li> <li>• Respiratory Sensitizer</li> <li>• Target Organ Toxicity</li> <li>• Aspiration Toxicity</li> </ul>	<p style="text-align: center;"><b>Flame</b></p>  <ul style="list-style-type: none"> <li>• Flammables</li> <li>• Pyrophorics</li> <li>• Self-Heating</li> <li>• Emits Flammable Gas</li> <li>• Self-Reactives</li> <li>• Organic Peroxides</li> </ul>	<p style="text-align: center;"><b>Exclamation Mark</b></p>  <ul style="list-style-type: none"> <li>• Irritant (skin and eye)</li> <li>• Skin Sensitizer</li> <li>• Acute Toxicity</li> <li>• Narcotic Effects</li> <li>• Respiratory Tract Irritant</li> <li>• Hazardous to Ozone Layer (Non-Mandatory)</li> </ul>
<p style="text-align: center;"><b>Gas Cylinder</b></p>  <ul style="list-style-type: none"> <li>• Gases Under Pressure</li> </ul>	<p style="text-align: center;"><b>Corrosion</b></p>  <ul style="list-style-type: none"> <li>• Skin Corrosion/Burns</li> <li>• Eye Damage</li> <li>• Corrosive to Metals</li> </ul>	<p style="text-align: center;"><b>Exploding Bomb</b></p>  <ul style="list-style-type: none"> <li>• Explosives</li> <li>• Self-Reactives</li> <li>• Organic Peroxides</li> </ul>
<p style="text-align: center;"><b>Flame Over Circle</b></p>  <ul style="list-style-type: none"> <li>• Oxidizers</li> </ul>	<p style="text-align: center;"><b>Environment (Non-Mandatory)</b></p>  <ul style="list-style-type: none"> <li>• Aquatic Toxicity</li> </ul>	<p style="text-align: center;"><b>Skull and Crossbones</b></p>  <ul style="list-style-type: none"> <li>• Acute Toxicity (fatal or toxic)</li> </ul>

## EMPLOYEE INFORMATION AND TRAINING

Employee training on specific workplace hazards must be provided at the time of initial assignment, whenever a new hazard is introduced into the workplace, and whenever employees may be exposed to hazards in other work areas (<http://ehs.uci.edu/SafetyTrainingSelf-AssessmentInstructions.pdf>). General Hazard Communication Training is available online through the Safety Training module (<http://www.uclc.uci.edu/>). The online Safety Training is not a substitution for Laboratory Safety Fundamental Concepts. Additional employee training is required whenever a new hazard is introduced into the work environment, and must be provided within 30 days of receiving the SDS or other safety information and before the employee starts work with said new hazard. All training must be in the appropriate language, educational level, and vocabulary for laboratory personnel. Employees must be given the opportunity to ask questions.

## LABORATORY HAZARD ASSESSMENT TOOL

The Laboratory Hazard Assessment Tool (LHAT), found at <https://ehs.ucop.edu/lhat> was developed to broadly identify activities involving chemical and other types of hazards and is an effective method of hazard communication. The Laboratory Hazard Assessment Tool captures information on the specific type of hazard(s), the location of the hazard(s), the name of the PI/Laboratory Supervisor who oversees the facility and helps identify the proper PPE that should be used by laboratory personnel to protect themselves against these hazards. Once the required PPE is identified, the laboratory is required to conduct and document training for laboratory personnel on the use of PPE.

## Other Resources

1. "Occupational Exposure to Hazardous Chemicals in Laboratories." California Code of Regulations (CCR) Title 8, Section 5191;
2. Standard Operating Procedures (SOPs) for handling toxic chemicals (Appendix C);
3. General information on the signs and symptoms associated with exposure to hazardous substances used in the laboratory or facility
  - Identity labels, showing contents of containers (including waste receptacles) and associated hazards;
  - Label hazardous waste containers. See the UCI EH&S website for hazardous waste management information (<http://www.ehs.uci.edu/programs/enviro/index.html>);
  - Warnings at areas or equipment where special or unusual hazards exist (e.g., particularly hazardous substances);
4. Procedures to follow in case of an emergency; including the posting of the "UCI Injuries and Medical Treatment" poster (<http://ehs.uci.edu/MedEmergPoster.pdf>)
  - Emergency telephone numbers of emergency personnel/facilities, supervisors, and laboratory workers; and
  - Location signs for safety showers, eyewash stations, other safety and first aid equipment, exits and areas where food and beverage consumption and storage are permitted.
  - Report injury, illness, or safety concern online : <https://www.ehs.uci.edu/apps/hr/index.jsp>
  - Work related injury and illness information available online: [https://login.uci.edu/ucinetid/webauth?return\\_url=https://portal.uci.edu/uPortal/Login%3FrefUri%3D%2FuPortal%2Fp%2Fwebproxy-cms-file-view.ctf1%2Fmax%2Frender.uP%253FpP\\_cmsUri%253Dpublic%25252FHumanResources%25252FWorkersCompensation%25252FmainMenuWorkersCompensation.xml](https://login.uci.edu/ucinetid/webauth?return_url=https://portal.uci.edu/uPortal/Login%3FrefUri%3D%2FuPortal%2Fp%2Fwebproxy-cms-file-view.ctf1%2Fmax%2Frender.uP%253FpP_cmsUri%253Dpublic%25252FHumanResources%25252FWorkersCompensation%25252FmainMenuWorkersCompensation.xml)

## Chapter 3: Classes of Hazardous Chemicals

### Regulatory Requirements

Implementation of the necessary work practices, procedures, and policies outlined in this chapter is required by the following:

- *Title 8, California Code of Regulations (CCR), Section 5194, "Hazard Communication"* (<http://www.dir.ca.gov/title8/5194.html>)
- *Title 8, CCR, Section 5209, "Carcinogens"* (<http://www.dir.ca.gov/title8/5209.html>)

Other applicable regulations include those promulgated by the U.S. Department of Labor including 29 CFR 1910.1450 "Occupational Exposure to Hazardous Chemicals in Laboratories" (the "Laboratory Standard").

### Identification & Classification of Hazardous Chemicals

Chemicals can be divided into several different hazard classes. The hazard class will determine how a chemical should be stored and handled and what special equipment and procedures are needed to use it safely.

Each chemical container, whether supplied by a vendor or produced in the laboratory, must include labels that clearly identify the hazards associated with that chemical, using the GHS. In addition to specific chemical labels, hazard information for specific chemicals can be found by referencing the Safety Data Sheet (SDS) for that chemical.

It is essential that all laboratory workers understand the types of hazards, recognize the routes of exposure, and are familiar with the major hazard classes of chemicals. In many cases, the specific hazards associated with new compounds and mixtures will not be known, so it is recommended that all chemical compounds be treated as if they were potentially harmful and to use appropriate eye, inhalation and body protection equipment at all times.

#### FLAMMABILITY HAZARDS

A number of highly flammable substances are in common use in campus laboratories. Flammable liquids include those chemicals that have a flashpoint of less than 200 degrees Fahrenheit. These materials must be stored in self-closing flammable storage cabinets in aggregate quantities of 10 gallons or more per room. If less than 10 gallons, flammables can be stored in regular cabinets. Flame-resistant laboratory coats must be worn when working with any amount of pyrophoric materials, when working with large quantities (1 liter or more) of flammable materials, and/or with procedures where a significant fire risk is present (e.g., when working with open flame, etc.) as described in the UCOP policy about PPE requirements found at <http://policy.ucop.edu/doc/3500597/PersonalProtectiveEquip>. Even though the use of these materials is fairly common in the laboratory setting, they can constitute a significant immediate threat and should be treated with particular care. Particular attention should be



given to preventing static electricity and sparks when handling flammable liquids. For example, a metal dispensing container should always be bonded and grounded when pouring or dispensing liquid to prevent the buildup of static electricity and prevent the formation of sparks which will cause a fire.

## REACTIVITY HAZARDS



Reactive and explosive substances are materials that decompose under conditions of mechanical shock, elevated temperature, or chemical action, and release large volumes of gases and heat. Some materials, such as peroxide formers, may not be explosive, but may form explosive substances over time. These substances pose an immediate potential hazard and procedures which use or produce them must be carefully reviewed. These materials must

also be stored in a separate flame-resistant storage cabinet or, in many cases, in laboratory grade refrigerator or freezer that are designed for flammable and reactive chemicals. Peroxide formers can only be stored in refrigerators when unopened.

**Never** store **opened** peroxide formers (e.g., ether) in a refrigerator or freezer!

Opened containers must be stored in a dry environment.



Pyrophoric chemicals are a special classification of reactive materials that spontaneously combust when in contact with air and require laboratory-specific training. Flame-resistant laboratory coats must always be worn at all times when working with reactive chemicals. These reactive chemicals have the potential to cause highly energetic reactions which may result in a fire or explosion. Materials that pose a reactivity hazard should be purchased in the smallest practical size.

## HEALTH HAZARDS

Cal/OSHA uses the following definition for health hazards:



The term 'health hazard' includes chemicals which are carcinogens, toxic or highly toxic agents, reproductive toxins, irritants, corrosives, sensitizers, hepatotoxins, nephrotoxins, neurotoxins, agents which act on the hematopoietic systems, and agents which damage the lungs, skin, eyes, or mucous membranes.



The major classes of "hazardous" and "particularly hazardous substances" and their related health and safety risks are detailed below. Extreme care should be taken to prevent exposure to these substances and immediate treatment should be sought upon possible exposure to chemicals which are health hazards.

### Corrosive Substances

As a health hazard, corrosive substances cause destruction of, or alterations in, living tissue by chemical action at the site of contact.

Major classes of corrosive substances include:

- Strong acids – e.g., sulfuric, nitric, hydrochloric and hydrofluoric acids
- Strong bases – e.g., sodium hydroxide, potassium hydroxide and ammonium hydroxide



- Dehydrating agents – e.g., sulfuric acid, sodium hydroxide, phosphorus pentoxide and calcium oxide
- Oxidizing agents – e.g., hydrogen peroxide, chlorine and bromine.

Corrosive materials should always be stored below eye level to reduce the probability of splashing the chemical into the eyes. Symptoms of inhalation exposure include a burning sensation, coughing, wheezing, laryngitis, shortness of breath, nausea, and vomiting. For eye exposures, symptoms include pain, blood shot eyes, tearing, and blurring of vision. For skin exposures, symptoms may include reddening, pain, inflammation, bleeding, irritation, blistering, and burns. As a physical hazard, corrosive substances may corrode materials they come in contact with and may be highly reactive with other substances. It is important to review information regarding the materials they may corrode, and their reactivity with other substances, as well as information on health effects. In most cases, these materials should be segregated from other chemicals and require secondary containment when in storage.

### **Irritants**

Irritants are defined as non-corrosive chemicals that cause reversible inflammatory effects on living tissue by chemical action at the site of contact. A wide variety of organic and inorganic compounds, including many chemicals that are in a powder or crystalline form, are irritants. The most common example of an irritant may be ordinary smoke which can irritate the nasal passages and respiratory system. Consequently, eye and skin contact with all laboratory chemicals should always be avoided. Symptoms of exposure can include reddening or discomfort of the skin and irritation to respiratory systems.



### **Sensitizers**

A sensitizer (allergen) is a substance that causes exposed people to develop an allergic reaction in normal tissue after repeated exposure to the substance. Examples of sensitizers include diazomethane, chromium, nickel, formaldehyde, isocyanates, arylhydrazines, benzylic and allylic halides, and many phenol derivatives. Sensitizer exposure can lead to all of the symptoms associated with allergic reactions, or can increase an individual's existing allergies. Caution should be taken when using these chemicals, eye and skin contact with all laboratory chemicals should always be avoided. However, inhalation of sensitizers can also lead to an allergic response; therefore it is recommended that sensitizers always be used in a fume hood or with proper ventilation. The material should be weighed in a balance that is located in a hood or in a location with proper ventilation to prevent inhalation. Never have an open container of a sensitizer outside of a fume hood or space with proper ventilation.



### **Hazardous Substances with Toxic Effects on Specific Organs**

Substances in this category include:

- Hepatotoxins – i.e., substances that produce liver damage, such as nitrosamines and carbon tetrachloride
- Nephrotoxins – i.e., agents causing damage to the kidneys, such as certain halogenated hydrocarbons



- Neurotoxins – i.e., substances which produce their primary toxic effects on the nervous system, such as mercury, acrylamide and carbon disulfide
- Hematopoietic agents – e.g., carbon monoxide and cyanides which decrease hemoglobin function and deprive the body tissues of oxygen
- Pulmonary agents – e.g., asbestos and silica.



Symptoms of exposure to these materials vary. Staff working with these materials should review the SDS for the specific material being used and should take special note of the associated symptoms of exposure.

## Particularly Hazardous Substances

OSHA recognizes that some classes of chemical substances pose a greater health and safety risk than others. To differentiate this different risk characteristic, OSHA identifies two categories of hazardous chemicals:

1. **Hazardous chemicals;** and
2. **Particularly hazardous substances.**

Substances that pose such significant threats to human health are classified as "particularly hazardous substances" (PHSs). The OSHA Laboratory Standard and Cal/OSHA regulation require that special provisions be established to prevent the harmful exposure of researchers to PHSs, including the establishment of designated areas for their use, waste disposal, and decontamination procedures.

See Safe Use of Particularly Hazardous Substances (Appendix D) for more information, which also includes a list of common particularly hazardous chemicals used inside laboratories.

Particularly hazardous substances are divided into three primary types:

1. **Acutely Toxic Chemicals**
2. **Reproductive Toxins**
3. **Carcinogens**

### ***Acutely Toxic Chemicals***

Substances that have a high degree of acute toxicity are interpreted by OSHA as being substances that "may be fatal or cause damage to target organs as the result of a single exposure or exposures of short duration. These chemicals, associated chemical waste, and storage containers must be handled with care to prevent cross contamination of work areas and unexpected contact. Extreme care should be taken to avoid any route of exposure (e.g., inhalation, skin contact, ingestion, injection). These chemicals must be labeled as "Toxic." Empty containers of these substances must be packaged and disposed of as hazardous waste without rinsing trace amounts into the sanitary sewer system. The SDS should be reviewed and understood prior to working with or handling toxic chemicals in the laboratory. Where applicable antidotes to a toxic substance must be on hand/easily accessible (ex: a lab with hydrofluoric acid **must** always have unexpired calcium gluconate) and every member of the lab must be aware of first aid measures in case of exposure.



### ***Reproductive Toxins***

Reproductive toxins include any chemical that may affect the reproductive capabilities, including chromosomal damage (mutations) and effects on fetuses (teratogenesis).

Reproductive toxins can affect the reproductive health of both men and women if proper procedures and controls are not used. For women, exposure to reproductive toxins during pregnancy can cause adverse effects on the fetus; these effects include embryolethality (death of the fertilized egg, embryo or fetus), malformations (teratogenic effects), and postnatal functional defects. For men, exposure can lead to sterility in addition to mutagenesis that can affect future generations.



Examples of embryotoxins include thalidomide and certain antibiotics such as tetracycline. Women of childbearing potential should note that embryotoxins have the greatest impact during the first trimester of pregnancy. Because a woman often does not know that she is pregnant during this period of high susceptibility, special caution is advised when working with all chemicals at all times, especially those rapidly absorbed through the skin (e.g., formamide). Pregnant women and women intending to become pregnant should consult with their laboratory supervisor and EH&S (<https://www.ehs.uci.edu/programs/ih/reproductivehealth.html>) before working with substances that are suspected to be reproductive toxins.

### ***Carcinogens***

Carcinogens are chemical or physical agents that cause cancer. Generally, they are chronically toxic substances; that is, they cause damage after repeated or long-duration exposure, and their effects may only become evident after a long latency period. Chronic toxins are particularly insidious because they may have no immediately apparent harmful effects.

These materials are separated into three classes:

1. **Select Carcinogens**
2. **Regulated Carcinogens**
3. **Listed Carcinogens**



**Select carcinogens** are materials which have met certain criteria established by the National Toxicology Program (NTP) or the International Agency for Research on Cancer (IARC) regarding the risk of cancer via certain exposure routes. It is important to recognize that some substances involved in research laboratories are new compounds and have not been subjected to testing for carcinogenicity. The following references (links provided) are used to determine which substances are select carcinogens by Cal/OSHA's classification:

- OSHA Carcinogen List (<https://www.osha.gov/SLTC/carcinogens/index.html>)
- Annual Report on Carcinogens published by the National Toxicology Program (NTP), including all of the substances listed as "known to be carcinogens" and some substances listed as "reasonably anticipated to be carcinogens" ([https://ntp.niehs.nih.gov/pubhealth/roc/previous\\_editions/](https://ntp.niehs.nih.gov/pubhealth/roc/previous_editions/) and [https://ntp.niehs.nih.gov/ntp/roc/content/listed\\_substances\\_508.pdf](https://ntp.niehs.nih.gov/ntp/roc/content/listed_substances_508.pdf))
- International Agency for Research on Cancer (IARC), including all of Group 1 "carcinogen to humans" by the International Agency for Research on Cancer Monographs (IARC) (Volumes 1-48 and Supplements 1-8); and some in Group 2A or 2B, "reasonably anticipated to be carcinogens" by the National Toxicology Program (NTP), and causes statistically significant tumor incidence in experimental animals in accordance with any of the following criteria: (i) after inhalation exposure of 6-7 hours per day, 5 days per week, for a significant portion of a lifetime to dosages of less than 10 mg/m<sup>3</sup>; (ii) after repeated skin application of less than 300 mg/kg of body weight per week; or (iii) after oral dosages of less than 50 mg/kg of body weight per day

(<https://monographs.iarc.fr/agents-classified-by-the-iarc/> and [https://monographs.iarc.fr/wp-content/uploads/2019/07/Classifications\\_by\\_cancer\\_site.pdf](https://monographs.iarc.fr/wp-content/uploads/2019/07/Classifications_by_cancer_site.pdf))

**Regulated Carcinogens** fall into a higher hazard class and have extensive additional requirements associated with them. The use of these agents may require personal exposure sampling based on usage. When working with Regulated Carcinogens, it is particularly important to review and effectively apply engineering and administrative safety controls as the regulatory requirements for laboratories that may exceed long term (8 hour) or short-term (15 minutes) threshold values for these chemicals are very extensive. Regulated carcinogens have been listed by Cal/OSHA ([https://www.chemistry.ucla.edu/sites/default/files/safety/doc/OSHA\\_Regulated\\_Carcinogens.pdf](https://www.chemistry.ucla.edu/sites/default/files/safety/doc/OSHA_Regulated_Carcinogens.pdf)) and by the State of California Department of Industrial Relations in Subchapter 7. General Industry Safety Orders, Group 16. Control of Hazardous Substances, Article 110. Regulated Carcinogens (<https://www.dir.ca.gov/title8/sb7g16a110.html>). Any spill, release of, or suspected exposure to a regulated carcinogen must be reported to EH&S (4-6200) immediately.

Since there are additional regulations for the use, handling, and storage of regulated carcinogens EH&S should be contacted (call 4-6200), prior to use or if the intended use changes.

**Listed Carcinogens** refer to a list of thirteen chemicals that are considered to pose the highest cancer hazard (<https://www.dir.ca.gov/title8/5209.html>). These materials have further requirements for their use in addition to the requirements for regulated carcinogens.

### **Chemicals Known to the State of California to Cause Cancer or Reproductive Toxicity**

The Safe Drinking Water and Toxic Enforcement Act of 1986, also known as **Proposition 65**, requires the State to publish a list of chemicals known to cause cancer or reproductive toxicity ([http://oehha.ca.gov/prop65/prop65\\_list/Newlist.html](http://oehha.ca.gov/prop65/prop65_list/Newlist.html)). This list is updated regularly and reviewed by two committees that are a part of The Office of Environmental Health Hazard Assessment's Science Advisory Board. The two committees are the Carcinogen Identification Committee (CIC) and Developmental and Reproductive Toxicant (DART) Identification Committee.

## **Nanomaterials**

The increasing use of nanomaterials in research labs warrants consideration of the hazards they may pose. As is the case with many new technologies, the health effects of nanomaterials have not been thoroughly investigated. Consequently, the uncertainty surrounding the toxicity of nanomaterials merits a cautious approach when working with them.

Nanomaterials include any materials or particles that have an external dimension in the nanoscale (~1 – 100 nm). Nanomaterials are both naturally occurring in the environment and intentionally produced. Intentionally produced nanomaterials are referred to as Engineered Nanomaterials (ENMs). Materials whose properties do not differ significantly between their nanoscale and larger forms are generally excluded from ENMs. The most common types of ENMs are carbon based materials (e.g., nanotubes), metals and metal oxides (e.g., silver and zinc oxide), and quantum dots (e.g., zinc selenide) (Table 3.1).

Nanomaterials can be categorized by the potential risk of exposure they pose to personnel based on the physical state of the materials and the conditions in which they are used (Table 3.2). In general, the risk of exposure is lowest when nanomaterials are bound in a solid matrix with little potential to create airborne dust or when in a non-volatile liquid suspension. The risk of exposure increases when nanomaterials are used as fine powders, are suspended in volatile solvents or gases, or in procedures in which aerosols may be produced. The parent compound of the nanomaterial should also be taken into consideration when evaluating the potential hazards associated with exposure (e.g., a highly toxic

compound such as cadmium should be anticipated to be toxic and possibly more toxic when used as a nanomaterial). However, some materials that are non-toxic in their bulk phase may display significant toxicity as nanomaterials, always take the necessary precautions to avoid exposure.

**Table 3.1 Types of Nanomaterials** (from page 5 of Nanotoolkit, [https://www.ehs.uci.edu/programs/sop\\_library/Nanotoolkit.pdf](https://www.ehs.uci.edu/programs/sop_library/Nanotoolkit.pdf))

<b>Carbon Based</b>	<b>Buckyballs or Fullerenes, Carbon Nanotubes*, Dendrimers</b> <i>Often includes functional groups like* PEG (polyethylene glycol), Pyrrolidine, N, N-dimethylethylenediamine, imidazole</i>
<b>Metals and Metal Oxides</b>	<b>Titanium Dioxide (Titania)**, Zinc Oxide, Cerium Oxide (Cerium), Aluminum oxide, Iron Oxide, Silver, Gold, and Zero Valent Iron (ZVI) nanoparticles</b>
<b>Quantum Dots</b>	<b>ZnSe, ZnS, ZnTe, CdS, CdTe, CdSe, GaAs, AlGaAs, PbSe, PbS, InP</b> <i>Includes crystalline nanoparticle that exhibits size-dependent properties due to quantum confinement effects on the electronic states (ISO/TS 27687:2008).</i>

\*Carbon Nanotubes are subject to a proposed Recommended Exposure Limit of TWA 7 µg/m<sup>3</sup> due to the risk of developing respiratory health effects.

\*\*Nano-Titanium Dioxide is subject to a proposed Permissible Exposure Limit of TWA 0.3 mg/m<sup>3</sup> due to the risk of developing lung cancer. There are mixed studies regarding TiO<sub>2</sub> skin penetration. Some studies indicate TiO<sub>2</sub> and ZnO does not pass through the stratum corneum [outer layer of the skin (epidermis)], while others indicate significant penetration through the skin.

See [https://www.ehs.uci.edu/programs/sop\\_library/Nanotoolkit.pdf](https://www.ehs.uci.edu/programs/sop_library/Nanotoolkit.pdf) for a detailed Standard Operating Procedure (SOP) template for working with nanomaterials that provides guidance on appropriate work practices, engineering controls, Personal Protective Equipment (PPE), and waste disposal practices depending on the risk level of a particular nanomaterial or process involving a nanomaterial.

For further information see the California Nanosafety Consortium of Higher Education’s “Nanotoolkit: Working Safely with Engineered Nanomaterials in Academic Research Settings” ([https://www.ehs.uci.edu/programs/sop\\_library/Nanotoolkit.pdf](https://www.ehs.uci.edu/programs/sop_library/Nanotoolkit.pdf)), the National Institute of Occupational Safety & Health’s (NIOSH) “Safe Practices for Working with Engineered Nanomaterials in Research Laboratories” (<http://www.cdc.gov/niosh/docs/2012-147/pdfs/2012-147.pdf>), and the National Institute of Occupational Safety & Health’s (NIOSH) “Current Strategies for Engineering Controls in Nanomaterial Production and Downstream Handling Processes” (<http://www.cdc.gov/niosh/docs/2014-102/pdfs/2014-102.pdf>).

**Table 3.2 Nanomaterial Risk Categories** (from page 10 of Nanotoolkit, [https://www.ehs.uci.edu/programs/sop\\_library/Nanotoolkit.pdf](https://www.ehs.uci.edu/programs/sop_library/Nanotoolkit.pdf))

Risk Level	Material State or Type of Use	Examples
<p><b>Category 1</b> Lower Exposure Potential</p>	<p><b>Material State</b></p> <ul style="list-style-type: none"> <li>• No potential for airborne release (when handling)</li> <li>• Solid: Bound in a substrate or matrix</li> <li>• Liquid: Water-based liquid suspensions or gels</li> <li>• Gas: No potential for release into air (when handling)</li> </ul> <p><b>Type of Use</b></p> <ul style="list-style-type: none"> <li>• No thermal or mechanical stress</li> </ul>	<ul style="list-style-type: none"> <li>• Non-destructive handling of solid engineered nanoparticle composites or nanoparticles permanently bonded to a substrate</li> </ul>
<p><b>Category 2</b> Moderate Exposure Potential</p>	<p><b>Material State</b></p> <ul style="list-style-type: none"> <li>• Moderate potential for airborne release (when handling)</li> <li>• Solid: Powders or Pellets</li> <li>• Liquid: Solvent-based liquid suspensions or gels</li> <li>• Air: Potential for release into air (when handling)</li> </ul> <p><b>Type of Use</b></p> <ul style="list-style-type: none"> <li>• Thermal or mechanical stress induced</li> </ul>	<ul style="list-style-type: none"> <li>• Pouring, heating, or mixing liquid suspensions (e.g., stirring or pipetting), or operations with high degree of agitation involved (e.g., sonication)</li> <li>• Weighing or transferring powders or pellets</li> <li>• Changing bedding out of laboratory animal cages</li> </ul>
<p><b>Category 3</b> Higher Exposure Potential</p>	<p><b>Material State</b></p> <ul style="list-style-type: none"> <li>• High potential for airborne release (when handling)</li> <li>• Solid: Powders or Pellets with extreme potential for release into air</li> <li>• Gas: Suspended in gas</li> </ul>	<ul style="list-style-type: none"> <li>• Generating or manipulating nanomaterials in gas phase or in aerosol form</li> <li>• Furnace operations</li> <li>• Cleaning reactors</li> <li>• Changing filter elements</li> <li>• Cleaning dust collection systems used to capture nanomaterials</li> <li>• High speed abrading / grinding nanocomposite materials</li> </ul>

# Chapter 4: How to Reduce Exposures to Hazardous Chemicals

## Regulatory Requirements

Implementation of the necessary work practices, procedures, and policies outlined in this chapter is required by the following:

- Title 8, California Code of Regulations (CCR), Section 5191, "Occupational Exposures to Hazardous Chemicals in Laboratories" (<http://www.dir.ca.gov/title8/5191.html>)
- Title 8, CCR, Section 5209, "Carcinogens" (<http://www.dir.ca.gov/title8/5209.html>)
- Title 8, CCR, Section 5154.1, "Ventilation Requirements for Laboratory-Type Hood Operations" ([http://www.dir.ca.gov/title8/5154\\_1.html](http://www.dir.ca.gov/title8/5154_1.html))

Other applicable regulations include those promulgated by the U.S. Department of Labor including 29 CFR 1910.1450 "Occupational Exposure to Hazardous Chemicals in Laboratories" (the "Laboratory Standard"; <https://www.osha.gov/laws-regs/regulations/standardnumber/1910/1910.1450>).

## Introduction

Hazardous chemicals require a carefully considered, multi-tiered approach to ensure safety. There are four primary routes of exposure for chemicals which have associated health hazards (illustrated in Figure 4.1):

1. Inhalation;
2. Absorption (through the skin or eyes);
3. Ingestion; and
4. Injection (skin being punctured by a contaminated sharp object or uptake through an existing open wound).

Of these, the most likely route of exposure in the laboratory is by inhalation. Inhalation can provide some materials with direct access to the bloodstream and/or central nervous system. Inhalation can also lead to ingestion if the inhaled materials became entrapped in mucus or saliva which are swallowed. Many hazardous chemicals may affect people through more than one of these exposure modes, so it is critical that protective measures are in place for each of these uptake mechanisms.

## Safety Controls

Safety controls are divided into five main classifications:

1. Elimination

Figure 4.1 – Routes of Exposure

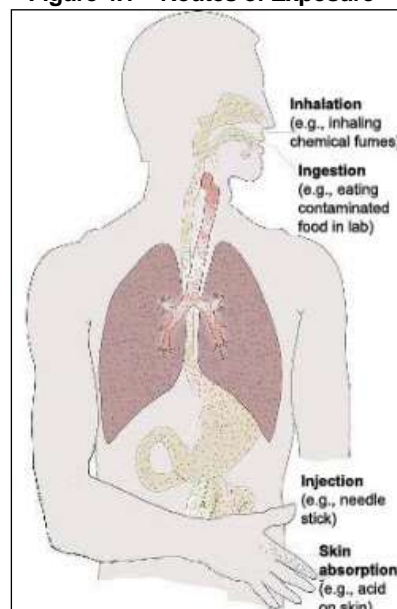

2. Substitution
3. Engineering Controls;
4. Administrative Controls; and
5. Protective Apparel and Equipment.

Elements of these five classes are used in a layered approach to create a safe working environment. The principles of each of these elements are detailed below.



## ELIMINATION AND SUBSTITUTION

Elimination and substitution are the most effective methods for mitigating hazards. Elimination is the most effective, if elimination is not possible, substitution to a less hazardous material is the next most effective method. Such as replacing mercury thermometers with alcohol thermometers or replacing hexane with heptane.

## ENGINEERING CONTROLS

Engineering controls include all “built in” safety systems. These controls offer the first line of protection after opportunities for elimination and substitution have been exhausted. Engineering controls are highly effective in that they generally require minimal special procedures or actions on the part of the user except in emergency situations. A fundamental and very common example is the laboratory fume hood which is very effective at containing chemical hazards and protecting users from inhalation hazards. Other examples of engineering controls include general room ventilation, flammable material storage units, and secondary containment.

### General Laboratory Ventilation

All laboratory rooms in which hazardous materials are used must have fresh air ventilation with 100% of the exhaust venting to the outside; laboratory rooms should not be part of recycled air systems. In cases where this is not desirable, a formal hazard evaluation will be made by EH&S to determine what work can be done in the space and under what special conditions or limitations. Laboratory rooms should be kept at negative pressure compared to public areas to prevent the spread of hazardous vapors. See the University of California Environment, Health and Safety (EH&S) Laboratory Safety Design Guide (<https://lscdm.ucop.edu/sections/laboratory-design-considerations>) for additional information on laboratory ventilation.

### Fume Hoods

Fume hoods are the most commonly used local exhaust system on campus. Other methods include vented enclosures for large pieces of equipment or chemical storage, and portable exhaust systems for capturing contaminants near the point of release. Some systems are equipped with air cleaning devices (HEPA filters or carbon absorbers). Exhaust from fume hoods are designed to terminate at least ten feet above the roof deck or two feet above the top of any parapet wall, whichever is higher. Figure 4.2 displays the key components of a fume hood.

Figure 4.2 – Fume Hood

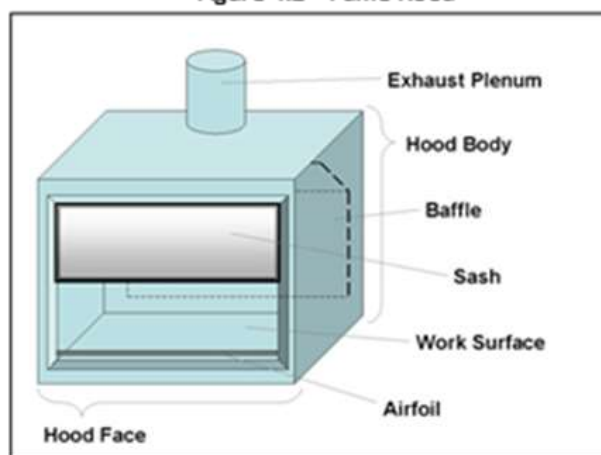

**It is advisable to use a laboratory hood when working with hazardous substances.** In addition, a laboratory fume hood or other suitable containment device must be used for all work with "particularly hazardous substances." A properly operating and correctly used laboratory fume hood can reduce or eliminate volatile liquids, dusts and mists. Fume hoods are evaluated for operation and certified by Roman Zaretsky (Zaretsky Engineering Solutions) on an annual basis. Laboratories must NEVER contact Zaretsky for certification. Certification must be coordinated through EH&S, call 4-6200. These annual evaluations check the fume hood air flow velocity to ensure that the unit will contain hazardous vapors. Data on annual fume hood monitoring will be maintained by EH&S. A complete report of fume hood monitoring data must be kept for one year; summary data must be maintained for 5 years.

Each fume hood should have a current calibration sticker and a marker indicating the highest sash height to be used when working with hazardous materials. Contact EH&S, 4-6200, for a hood evaluation if these labels are missing or if the working height is lower than reasonable (typical working height is ~18 inches from the base of the fume hood).

Air flow for fume hood ventilation is measured at nine points. The average of the nine readings must be at least 100 linear feet per minute (fpm) with a minimum of 70 fpm for any measurement. The average face velocity should not exceed 160 fpm.

Each fume hood must be equipped with at least one type of continuous quantitative monitoring device designed to provide the user with current information on the operational status of the hood. Many hoods also have motion sensors to determine when they are not in active use. These sensors will reduce the fume hood's air flow as part of the campus' energy savings effort. When hazardous materials are in a fume hood, but it is not under active use (e.g., during an unattended reaction or experiment), the sash should be closed. NEVER store hazardous materials in a fume hood. Some particularly hazardous chemicals or corrosive substances will corrode the fume hood and the duck work (e.g., acid).

Routine maintenance and repairs of fume hoods are conducted by Facilities Management, submit a work order to <https://service.fac.uci.edu/html/en/default/platform/mainpage/mainpage.jsp>. However, in most cases, the fume hood must be cleared by EH&S prior to commencement of repairs. The user may initiate the clearance request by completing the online form: <https://www.ehs.uci.edu/apps/pimoves/index.jsp>. The user will receive further instruction after initiating the clearance request. EH&S does not initiate maintenance but will coordinate with Facilities Management to ensure its completion. An electronic notification is generated by Facilities Management after the work order is completed.



## General Rules for Fume Hood Use

The following general rules should be followed when using laboratory hoods:

1. Fume hoods must not be used for work involving hazardous substances unless they have a certification label that confirms certification has occurred within the past year.
2. Always keep hazardous chemicals more than 6 inches behind the plane of the sash.
3. **Never** put your head inside an operating laboratory hood. The plane of the sash is the barrier between contaminated and uncontaminated air.
4. Work with the hood sash in the **lowest practical position**. The sash acts as a physical barrier in the event of an accident. Keep the sash closed when not conducting work in the hood.
5. Do not clutter your hood with unnecessary bottles or equipment that can block air circulation. Keep it clean and clear. Only materials actively in use should be in the hood.
6. Do not make any modifications to hoods, duct work, or the exhaust system. If there is a problem with your hood contact the EH&S office.
7. Do not use large equipment in laboratory hoods unless the hood is dedicated for this purpose, as large obstructions can change the airflow patterns and render the hood unsafe.
8. Shut your sash! For energy efficiency, make sure to shut your sash when the hood is not in use.

Laboratory fume hoods are one of the most important pieces of equipment used to protect laboratory and other workers from exposure to hazardous chemicals. Chemical fume hoods should be inspected upon installation, renovation, when a deficiency is reported, or a change has been made to the operating characteristics of the hood. Since fume hoods used for listed carcinogens have additional requirements, such as increased face velocity (average of 150 fpm, with no measurement less than 100 fpm), contact EH&S, 4-6200, if the intended use changes or if the hood is not operating properly for its intended use.

## Fume Hood Inspections

### ***Step 1 – Physical Inspection***

Evaluates the physical condition of the hood and the materials being used in the hood. This includes checking for:

- Improper storage of materials inside the fume hood
- Use of proper materials
- General hood cleanliness
- Physical damage to the fume hood (e.g., broken or cracked sash)
- Fully functioning lighting, fume hood indicator, airflow monitor, and alarm

### ***Step 2 – Hood Performance Inspection***

Evaluates the overall hood performance to ensure that it is functioning properly. This involves checking the:

- Average face velocity and set minimum face velocity, which is used to determine the rating of the hood and what the hood can be used for
- Noise generated by the fume hood, to ensure that it is below 85 dB
- If fume hood does not pass inspection, the yellow inspection tag will state "FAIL" on it.
  - Do not work in a hood if the tag says "FAIL," immediately contact EH&S.

## Glove Boxes and Ventilation Devices

In addition to fume hoods, some laboratories use contained glove box units for working with reactive chemicals under an inert environment, working with very toxic substances in a completely closed system, or for creating a stable, breeze free, system for weighing hazardous or reactive materials. These units can be very effective because they offer complete containment. When applicable

gloveboxes are the preferred method for using and storing pyrophoric and water-reactive chemicals. Figure 4.3 displays the key components of a glovebox.

Figure 4.3 – Glovebox

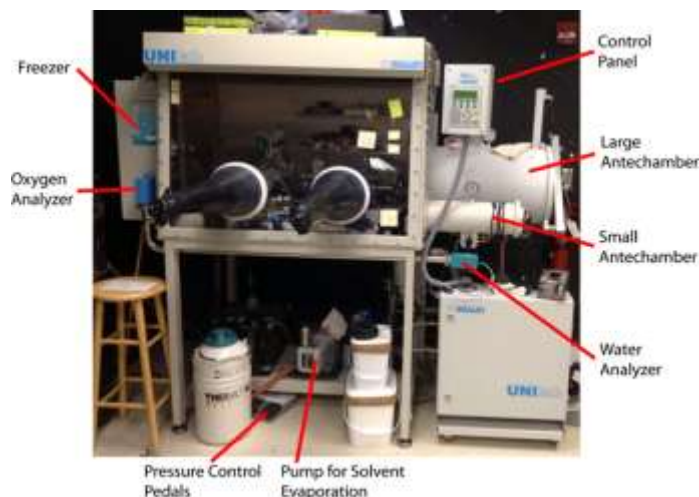

## Other Engineering Controls

In addition to the elements listed above, consideration must be given to providing sufficient engineering controls for the storage and handling of hazardous materials. No more than 10 gallons of flammable chemicals may be stored outside of an approved flammable storage cabinet. For refrigerated or frozen storage, flammable and explosive materials must be kept in explosion proof refrigeration units specifically designed for storing these materials. Generally these units do not have internal lights or electronic systems that could spark and trigger an ignition; additionally, the cooling elements are external to the unit. These units should be labeled with a rating from Underwriters Laboratory or other certifying organization.

Secondary containment must be provided for corrosive and reactive chemicals and is strongly recommended for all other hazardous chemicals. Secondary containment should be made of chemically resistant materials and should be sufficient to hold 100% of the largest container's volume OR 10% of the aggregate volumes of all containers, whichever is greater.

Laboratories that use hazardous materials must contain a sink, kept clear for hand washing to remove any final residual contamination. This sink must have soap present to allow for effective hand washing. Hand washing with soap is recommended whenever a staff member who has been working with hazardous materials plans to exit the laboratory or work on a project that does not involve hazardous materials.

## ADMINISTRATIVE CONTROLS

The next layer of safety controls are Administrative Controls. These controls consist of policies and procedures; they are not generally as reliable as engineering controls in that the user has to carefully follow the appropriate procedures and must be fully trained and aware in order to do so.

EH&S requires that each laboratory have safety procedures, which include safety practices, for any work that involves hazardous materials. These safety procedures should be laboratory specific and communicated via lab specific trainings, Standard Operating Procedures, or Job Safety Analyses and properly documented.

## Standard Operating Procedures

Standard operating procedures (SOPs) (Appendix C) or Job Safety Analysis (JSAs) that are relevant to safety and health considerations must be developed and followed when laboratory work involves the use of hazardous chemicals [CCR, Title 8, Section 5191 (e)(3)(A)], special attention should be made when working with “particularly hazardous substances” (PHS). SOPs are written instructions that detail the steps that will be performed during a given experimental procedure and include information about potential hazards and how these hazards will be mitigated. SOPs should be written by laboratory personnel who are most knowledgeable and involved with the experimental process, and the PI/ Laboratory Supervisor should approve all SOPs used in their laboratory. The development and implementation of SOPs is a core component of promoting a strong safety culture in the laboratory and helps ensure a safe work environment.

While general guidance regarding laboratory work with chemicals is contained in this plan, PIs/Laboratory Supervisors are required to develop and implement laboratory-specific SOPs for certain processes, hazardous chemicals and PHS that are used in their laboratories. The Principal Investigator and all personnel are responsible for performing the procedures detailed in the SOP, and they shall sign the SOP acknowledging the contents, requirements and responsibilities outlined in the SOP. The SOPs shall be reviewed by qualified personnel and shall be amended and subject to additional review and approval by the Principal Investigator where changes or variations in conditions, methodologies, equipment, or use of the chemical occurs. For certain hazardous chemicals, PHS, or specialized practices, consideration must be given to whether additional consultation with safety professionals is warranted or required.

Circumstances requiring prior approval from the PI/Laboratory Supervisor must also be addressed in laboratory specific SOPs. These circumstances are based on the inherent hazards of the material being used, the hazards associated with the experimental process, the experience level of the worker, and the scale of the experiment. Some examples of circumstances that may require prior approval include working alone in a laboratory, unattended or overnight operations, the use of highly toxic gases of any amount, the use of large quantities of toxic or corrosive gases, the use of extremely reactive chemicals (e.g., pyrophorics, water reactive chemicals), or the use of carcinogens.

The UCI EH&S maintains a website ([http://www.ehs.uci.edu/programs/sop\\_library/index.html](http://www.ehs.uci.edu/programs/sop_library/index.html) ) with tools and resources that may be referenced while developing SOPs. EH&S is also available to assist with the development of SOPs. SOPs must be developed prior to initiating any experiments with hazardous chemicals or PHS and are to be filed and maintained in the **Laboratory Safety Binder** where they are available to all laboratory personnel.

When drafting an SOP, consider the type and quantity of the chemical being used, along with the frequency of use. The Safety Data Sheet (SDS) for each hazardous chemical that will be addressed in the SOP should be referenced during SOP development. The SDS lists important information that will need to be considered, such as exposure limits, type of toxicity, warning properties, and symptoms of exposure. If a new chemical will be produced during the experiment, an SDS will not necessarily be available. In these cases, the toxicity is unknown and it must be assumed that the substance is particularly hazardous, as a mixture of chemicals will generally be more toxic than its most toxic component.

## PROTECTIVE APPAREL AND EQUIPMENT

### Personal Protective Equipment

Personal protective equipment (PPE) serves as a researcher's last line of defense against chemical exposures and is required by everyone entering a laboratory containing hazardous chemicals. Specific minimum requirements for PPE use, for chemical operations, are determined by the UCOP PPE policy at <http://policy.ucop.edu/doc/3500597/PersonalProtectiveEquip>.

The PPE policy outlines the basic PPE requirements, which include but are not limited to:

- Full length pants and close-toed shoes, or equivalent (Confine any loose clothing and long hair)
- Protective gloves, laboratory coats, & eye protection when working with, or adjacent to, hazardous chemicals
- Flame-resistant laboratory coats should be used during work with materials that pose a fire hazard including but not limited to pyrophoric substances, and more than 1 liter of flammables or when working in the presence of an ignition source or open flame.
- When using or quenching pyrophoric materials you must use inner nomex gloves (fire resistant glove liner, yellow) and neoprene outer gloves (chemical resistant outer glove, green). The appropriate gloves are shown below.



The primary goal of basic PPE is to mitigate, at a minimum, the hazard associated with exposure to hazardous substances. In some cases, additional, or more protective, equipment must be used. If a project involves a chemical splash hazard, chemical goggles are required; face shields may also be required when working with chemicals that may cause immediate skin damage (safety glasses must be worn under a face shield). Safety goggles differ from safety glasses in that they form a seal with the face, which completely isolates the eyes from the hazard. If a significant splash hazard exists, heavy gloves, protective aprons and sleeves may also be needed. Gloves should only be used under the specific condition for which they are designed, as no glove is impervious to all chemicals. Familiarize yourself with the glove permeability chart below to choose the appropriate glove for every hazardous material (<https://cloudfront.ualberta.ca/-/media/ualberta/vice-president-finance/environment-health-safety/documents/ansell8theditionchemicalresistanceguide-1.pdf>).

# 8th Edition Permeation/Degradation Resistance Guide for Ansell Gloves

The first square in each column for each glove type is color coded to provide an overall rating for both Degradation and Permeation. The letter in each colored square is for Degradation alone.

**GREEN:** The glove is very well suited for application with that chemical.

**YELLOW:** The glove is suitable for that application under careful control of its use.

**RED:** Avoid use of the glove with this chemical.

**SPECIAL NOTE:** The chemicals in this guide highlighted in BLUE are experimental carcinogens, according to the ninth edition of the Occupational Safety and Health's Hazardous Properties of Industrial Materials. Chemicals highlighted in GRAY are listed as suspected carcinogens, experimental carcinogens at extremely high dosages, and other materials which pose a lesser risk of cancer.

CHEMICAL	LAMINATE FILM		NITRILE		UNDISPONIBLE NEOPRENE		SUPPORTED POLYVINYL ALCOHOL		POLYVINYL CHLORIDE (PVC)		NATURAL RUBBER		NEOPRENE/NATURAL RUBBER BLEND		BUTYL UNSUPPORTED		NITRILE/UNDISPONIBLE	
	HAZARD**	PERMEATION	HAZARD**	PERMEATION	HAZARD**	PERMEATION	HAZARD**	PERMEATION	HAZARD**	PERMEATION	HAZARD**	PERMEATION	HAZARD**	PERMEATION	HAZARD**	PERMEATION	HAZARD**	PERMEATION
1. Acetaminophen	▲	>480	▲	>480	▲	>480	▲	>480	▲	>480	▲	>480	▲	>480	▲	>480	▲	>480
2. Acetic Acid, Glacial, 99.7%	▲	140	▲	150	▲	390	▲	19	▲	46	▲	110	▲	260	▲	>480	▲	>480
3. Acetone	▲	>480	▲	>480	▲	19	▲	143	▲	<5	▲	18	▲	10	▲	>480	▲	80
4. Acetonitrile	▲	>480	▲	30	▲	20	▲	150	▲	>480	▲	4	▲	13	▲	>480	▲	20
5. Acrylic Acid	▲	>480	▲	120	▲	300	▲	>480	▲	>480	▲	80	▲	67	▲	>480	▲	>480
6. Acrylonitrile	▲	>480	▲	>480	▲	>480	▲	>480	▲	>480	▲	5	▲	5	▲	>480	▲	>480
7. Aflatoxin	▲	>480	▲	140	▲	140	▲	>480	▲	60	▲	16	▲	20	▲	>480	▲	>480
8. Ammonia Gas	▲	19	▲	>480	▲	>480	▲	>480	▲	27	▲	>480	▲	27	▲	>480	▲	>480
9. Ammonium Fluoride, 40%	▲	>480	▲	>480	▲	>480	▲	>480	▲	>480	▲	>480	▲	>480	▲	>480	▲	>480
10. Ammonium Hydroxide, Conc. (28-30% Ammonia)	▲	30	▲	>480	▲	250	▲	>480	▲	240	▲	90	▲	247	▲	>480	▲	>480
11. n-Butyl Acetate	▲	470	▲	190	▲	>480	▲	>480	▲	>480	▲	>480	▲	>480	▲	120	▲	>480
12. n-Butyl Alcohol	▲	>480	▲	>480	▲	340	▲	190	▲	12	▲	25	▲	52	▲	>480	▲	>480
13. Benzene	▲	>480	▲	>480	▲	140	▲	>480	▲	62	▲	25	▲	82	▲	>480	▲	>480
14. Aqua Regia	▲	>480	▲	>480	▲	>480	▲	>480	▲	120	▲	>480	▲	190	▲	>480	▲	>480
15. Benzothiazole	▲	>480	▲	>480	▲	>480	▲	>480	▲	10	▲	16	▲	27	▲	>480	▲	100
16. Benzene (Hexane)	▲	>480	▲	>480	▲	>480	▲	>480	▲	>480	▲	>480	▲	>480	▲	>480	▲	250
17. Benzotrifluoride	▲	>480	▲	>480	▲	>480	▲	>480	▲	>480	▲	>480	▲	>480	▲	>480	▲	>480
18. Benzothiazolone	▲	>480	▲	170	▲	>480	▲	>480	▲	18	▲	58	▲	>480	▲	>480	▲	>480
19. Bromine Water	▲	>480	▲	>480	▲	>480	▲	>480	▲	>480	▲	>480	▲	>480	▲	>480	▲	>480
20. 1-Bromopropane (Propyl Bromide)	▲	>480	▲	22	▲	110	▲	>480	▲	16	▲	10	▲	10	▲	10	▲	10
21. 2-Bromopropane (Isopropyl Bromide)	▲	>480	▲	120	▲	400	▲	>480	▲	190	▲	190	▲	190	▲	>480	▲	190
22. n-Butyl Acetate	▲	>480	▲	75	▲	>480	▲	>480	▲	>480	▲	>480	▲	>480	▲	80	▲	>480
23. n-Butyl Alcohol	▲	>480	▲	>480	▲	270	▲	75	▲	190	▲	36	▲	75	▲	>480	▲	>480
24. Butyl Carbitol	▲	>480	▲	>480	▲	190	▲	>480	▲	397	▲	44	▲	148	▲	>480	▲	>480
25. Butyl Cellosolve	▲	>480	▲	470	▲	190	▲	130	▲	60	▲	85	▲	85	▲	>480	▲	>480
26. gamma-Butyrolactone	▲	>480	▲	>480	▲	340	▲	130	▲	>480	▲	60	▲	164	▲	>480	▲	>480
27. Carbon Disulfide	▲	>480	▲	30	▲	>480	▲	>480	▲	>480	▲	>480	▲	>480	▲	>480	▲	130
28. Carbon Tetrachloride	▲	>480	▲	140	▲	>480	▲	>480	▲	25	▲	7	▲	7	▲	>480	▲	>480
29. Cellulose** (Ethyl Glycol Ethox. 2-Ethoxyethanol)	▲	>480	▲	390	▲	120	▲	75	▲	38	▲	25	▲	25	▲	>480	▲	400
30. Cellulose Acetate** (2-Ethoxyethyl Acetate, EGAA)	▲	>480	▲	90	▲	40	▲	>480	▲	18	▲	25	▲	25	▲	>480	▲	165

It is also important to note that gloves degrade over time, so they should be replaced frequently to ensure adequate protection. Never reuse gloves and never touch your gloves to any surface that should not be contaminated (e.g., your phone, your skin, non-laboratory work surfaces). The EH&S website provides PPE selection guidance (<https://www.ehs.uci.edu/programs/PPE/LabPPE.html>) to assist in selecting the appropriate PPE for the type of potential hazard.

EH&S requires each laboratory to complete their Laboratory Hazard Assessment Tool (LHAT) prior to beginning work and to provide annual updates thereafter. PPE can be selected based on this hazard assessment. The online Laboratory Hazard Assessment Tool can be accessed at: <https://ehs.ucop.edu/lhat/>

## How to Use and Maintain PPE

Personal protective equipment should be kept clean and stored in an area where it will not become contaminated. Personal protective equipment should be inspected prior to use to ensure it is in good condition. It should fit properly and be worn properly. If it becomes contaminated or damaged, it should be cleaned or repaired when possible, or discarded and replaced. Lab coats and gloves should never be worn outside of the lab area.

## Contaminated Clothing/PPE

In cases where spills or splashes of hazardous chemicals on clothing or PPE occur, the clothing/PPE should immediately be removed and placed in a closed container that prevents release of the chemical. Heavily contaminated clothing/PPE resulting from an accidental spill and PPE contaminated with particularly hazardous substances should be disposed of as hazardous waste. Non-heavily contaminated laboratory coats should be cleaned and properly laundered, as appropriate. Laboratory

personnel should **never** take contaminated items home for cleaning or laundering. Persons or companies hired to clean contaminated items must be informed of potentially harmful effects of exposure to hazardous chemicals and must be provided with information to protect themselves.

## Respiratory Protection

Typically, respiratory protection is not needed in a laboratory. Under most circumstances, safe work practices, small scale usage, and engineering controls (fume hoods, biosafety cabinets, and general ventilation) adequately protect laboratory workers from chemical and biological hazards. Under certain circumstances, however, respiratory protection may be needed. These can include:

- An accidental spill such as:
  - a chemical spill outside the fume hood
  - a spill of biohazardous material outside a biosafety cabinet
- Performance of an unusual operation that cannot be conducted under the fume hood or biosafety cabinet
- When weighing powdered chemicals or microbiological media outside a glove box or other protective enclosure. Disposable filtering face-piece respirators are generally recommended for nuisance dusts. If the chemicals are toxic, contact EH&S for additional evaluation
- When exposure monitoring indicates that exposures exist that cannot be controlled by engineering or administrative controls
- As required by a specific laboratory protocol or as defined by applicable regulations
- If an individual has developed a sensitivity/allergy to specific chemicals

Because there are numerous types of respirators available, and each has specific limitations and applications, respirator selection and use requires pre-approval by EH&S. For either required or voluntary use of a respirator, the employee must fill out the Respiratory Hazard Assessment form (Appendix E), review it with their supervisor, and email to **[safety@uci.edu](mailto:safety@uci.edu)**. EH&S will contact the employee to evaluate the potential exposure. The review will include an evaluation of the work area and activities for the following:

- Provision of additional ventilation controls or enclosure of the airborne hazard
- Substitution with a less hazardous substance
- Qualitative or quantitative exposure assessment
- Respirator usage

Tasks with potential airborne hazards that cannot be eliminated by engineering or administrative controls will not be authorized by EH&S until affected employees can be incorporated into UCI's Respiratory Protection Program at **<http://www.ehs.uci.edu/programs/ih/respiratory.html>**.

If EH&S recommends respirator use for a task, the employee must first enroll in the next available Respirator Training and Fit Testing offered through EH&S. These classes contain the three components required by Cal/OSHA: medical evaluation, training and fit testing. The class schedule is available on the UC Learning Center website (<http://www.uclc.uci.edu/>). Employees must complete all components prior to starting work that requires respirator use.

Because wearing respiratory equipment places a physical burden on the user, laboratory workers must be medically evaluated prior to wearing respiratory equipment. Certain individuals (e.g., persons with severe asthma, heart conditions, or claustrophobia) may not be medically qualified to wear a respirator. Upon enrollment in Respirator Training and Fit Testing, the employee will be sent the appropriate medical questionnaire. The completed medical questionnaire will be evaluated by a licensed health

care professional before the employee proceeds with the training. NOTE: This medical questionnaire is confidential. The employee will be provided additional information on how to contact the licensed health care professional for follow up questions.

After successful completion of the medical evaluation, the employee will be trained and fit tested by EH&S. Training topics include:

- Why the respirator is necessary and how improper fit, usage, or maintenance can compromise the protective effect of the respirator
- What the limitations and capabilities of the respirator include/exclude
- How to use the respirator effectively in emergency situations, including situations in which the respirator malfunctions
- How to inspect, put on and remove, use, and check the seals of the respirator
- What the procedures are for maintenance and storage of the respirator
- How to recognize medical signs and symptoms that may limit or prevent the effective use of respirators
- The general requirements of the respiratory program

Finally, a qualitative or quantitative fit test is conducted by EH&S for each respirator user. The fit test ensures a proper face-to-face piece seal for each individual and their mask. Fit testing is done in accordance with UCI's Respiratory Protection Program and Cal/OSHA regulations (8 CCR 5144) (<http://www.dir.ca.gov/title8/5144.html>).

An annual refresher is required for the medical evaluation, respirator training, and fit testing. In addition to the annual training refresher, a more frequent re-training, fit testing or medical evaluation must be performed when any of the following occur:

- Changes in the workplace or the type of respirator render previous training obsolete
- Inadequacies in the employee's knowledge or use of the respirator indicate that the employee has not retained the requisite understanding or skill
- Any other situation arises in which reevaluation appears necessary to ensure safe respirator use
- Facial scarring, dental changes, cosmetic surgery, or an obvious change in body weight
- An employee reports medical signs or symptoms related to their ability to use a respirator

## **Laboratory Safety Equipment**

New personnel must be instructed in the location of fire extinguishers, safety showers, and other safety equipment *before* they begin work in the laboratory. This training is considered part of the laboratory specific training that all staff members must attend. UCI EH&S has provided a checklist which should be incorporated into the laboratory orientation for new personal, <http://www.ehs.uci.edu/programs/labres/LaboratorySiteSafetyOrientationChecklist.docx>.

### **Fire Extinguishers**

All laboratories working with combustible or flammable chemicals must be outfitted with appropriate fire extinguishers. All extinguishers should be mounted on a wall in an area free of clutter or stored in a fire extinguisher cabinet. Research personnel should be familiar with the location, use and classification of the extinguishers in their laboratory.

Laboratory personnel are not required to extinguish fires that occur in their work areas and should not attempt to do so unless:

- It is a small fire (i.e., small trash can sized fire or small fire in a fume hood)
- Appropriate fire extinguisher training has been received (<http://www.uclc.uci.edu/>)
- It is safe to do so



Any time a fire extinguisher is used, no matter for how brief a period, the PI/Laboratory Supervisor, or most senior laboratory personnel present at the time of the incident, must immediately report the incident to EH&S x4-6200. The fire extinguisher will need to be refilled as soon as possible. In the case of an emergency call 911 and pull the fire alarm.

### Safety Showers and Eyewash Stations



All laboratories using hazardous chemicals must have immediate access to safety showers with eye wash stations. Access must be available in **10 seconds** or less for a potentially injured individual and access routes must be kept clear. Safety showers must have a minimum clearance of 16 inches from the centerline of the spray pattern in all directions at all times; this means that no objects should be stored or left within this distance of the safety shower. Sink based eyewash stations and drench hoses are not adequate to meet this requirement and can only be used to support an existing compliant system. Additionally, keg-type shower/eyewash systems are only acceptable as a temporary solution and are not intended to replace emergency safety showers/eyewash stations.

In the event of an emergency, individuals using the safety shower/eyewash should be assisted by an uninjured person to aid in decontamination and should be encouraged to stay in the safety shower/eyewash for 15 minutes to remove all hazardous material.

Safety shower/eyewash stations are tested by Facilities Management on a monthly basis. Any units which do not have a testing date within one month should be reported immediately to EH&S, x4-6200. If an eyewash or safety shower needs repair, call Facilities Management Trouble Call at x4-5444 and give the operator the specific location of the defective equipment. Facilities

Online Services Requests that have been generated as a result of a health and safety deficiency, such as this, must be flagged as “URGENT”. A system has been implemented to expedite these Online Services Requests.

### Fire Doors

Many areas of research buildings may contain critical fire doors as part of the building design. These doors are an important element of the fire containment system and should remain closed unless they are on a magnetic self-closing or other automated self-closing system.



## Fire Sprinklers

The Fire Marshal has ordered that pyrophoric chemicals may only be stored and used in laboratories located in buildings that are fully equipped with a sprinkler system. This requirement applies irrespective of whether the pyrophoric chemical is stored and/or handled within a glovebox. Storage or work with pyrophoric materials is not permitted in buildings that do not have the necessary fire sprinkler system.



## Safe Laboratory Habits

As detailed above, a safety program must include layers of policies and protective equipment to allow for a safe working environment, but to achieve effectiveness, a number of fundamental elements must become basic working habits for the research community. Some of these elements are detailed below:

### Personal Protective Equipment:

- Wear closed-toe and closed-heel shoes, full length pants or equivalent as determined by the Laboratory Hazard Assessment Tool and UCOP PPE policy, at all times when in the laboratory
- Utilize appropriate PPE while in the laboratory and while performing procedures that involve the use of hazardous chemicals or materials
- Confine long hair, loose clothing, and accessories
- Remove laboratory coats or gloves immediately upon significant contamination, as well as before leaving the laboratory
- Avoid use of contact lenses in the laboratory unless necessary. If they are used, inform supervisor so special precautions can be taken
  - If researchers do wear contact lenses they should be aware that fumes from concentrated acids and solvents can cause eye irritation and damage to lenses. If eye irritation does occur immediately remove contact lenses and rinse eyes with clean water
- Use any other protective and emergency apparel and equipment as appropriate. Be aware of the locations of first aid kits and emergency eyewash and shower station
- Change gloves often
- Wear the appropriate gloves for the hazardous material or process.
- Never touch your gloves to any surface that should not be contaminated (e.g., your face, your phone, your computer). Always remove your gloves before touching a surface that should not be contaminated.
- Keep your lab coat buttoned when working in the laboratory.
- Remove your laboratory coat when leaving the laboratory and wash your hands with soap and water. Laboratory coats should never be worn outside of the laboratory and never within the clean areas in the laboratory.
- Never wear or store your laboratory coat in a non-laboratory area, or a clean-area in the laboratory. Never sit at your desk in a clean-area with your laboratory coat on.



## Chemical Handling:

- Use the smallest amount of chemical needed for the experiment. Only use the amount of chemical that is appropriate for the available ventilation system.
- Any apparatus that may contain or discharge toxic chemicals (pumps, distillation systems, solvent traps) must exhaust into local exhaust systems (e.g., fume hood) not into the laboratory.
- Properly label and store all chemicals. Always read all labels and warning signs.
- Use secondary containment at all times.
- Deposit chemical waste in appropriately labeled receptacles and follow all other waste disposal procedures of the Chemical Hygiene Plan.
- Do not allow release of toxic substances or fumes into rooms that re-circulate the atmosphere (e.g., cold or warm rooms).
- Do not smell or taste chemicals.
- Never use mouth suction for pipetting or starting a siphon.
- Do not dispose of any hazardous chemicals through the sewer system. These substances might interfere with the biological activity of wastewater treatment plants, create fire or explosion hazards, cause structural damage or obstruct flow.
- Be prepared for an accident or spill and refer to the emergency response procedures for the specific material. Procedures should be readily available to all personnel. Information on minor chemical spill mitigation may also be referenced in Appendix I. For general guidance, the following situations should be addressed:
  - Eye Contact: Promptly flush eyes with water for a prolonged period (15 minutes) and seek medical attention
  - Skin Contact: Promptly flush the affected area with soap and water (15 minutes) and remove any contaminated clothing. If symptoms persist after washing, seek medical attention

## Equipment Storage and Handling:

- Use equipment only for its intended/designed purpose
- Store laboratory glassware with care to avoid damage. Use extra care with Dewar flasks and other evacuated glass apparatuses. Evacuated glass apparatuses including Dewar flasks should be shielded or wrapped to contain chemicals and fragments should implosion occur. This type of wrapping can include a plastic casing or a strong layer of tape
- Use certified fume hoods, glove boxes, or other ventilation devices for operations which might result in release of toxic chemical vapors or dust. Preventing the escape of these types of materials into the working atmosphere is one of the best ways to prevent exposure
  - Balances for these materials should also be located in a certified fume hoods, glove boxes, or other ventilation device
- Keep hood sash closed when you are not working in the hood
- Do not use damaged glassware or other equipment
- Do not use uncertified fume hoods or glove boxes for hazardous chemical handling
- Avoid storing materials in hoods
- Do not allow the vents or air flow to be blocked
- All electrical equipment should be grounded and kept in good condition



## Laboratory Operations:

- Keep the work area clean and uncluttered, never have unnecessary materials or equipment in the work area



- Seek information and advice about hazards, plan appropriate protective procedures, and plan positioning of equipment before beginning any new operation
- If unattended operations are unavoidable, and have been approved by the PI/Laboratory Supervisor, place an appropriate sign on the door, leave lights on, and provide for containment of toxic substances in the event of failure of a utility service (such as cooling water)
- Be alert to unsafe conditions and ensure that they are corrected when detected
- Research staff and students must participate in both general training and lab specific training
- Research staff and students should never work alone on procedures involving hazardous chemicals, biological agents, or physical hazards
- Do not engage in distracting behavior such as practical jokes in the laboratory. This type of conduct may confuse, startle, or distract another worker
- Cover all cuts, abrasions, open sores, and bruises with waterproof tape and/or a bandage and disposable gloves, always report all injuries to your supervisor
- Keep all corridors doorways, and emergency exits clear and accessible
- Understand the procedures in case of an emergency (e.g., fire, earthquake, explosion, etc.)
- If minors are in the laboratories always follow the UC's Policy on Minors in Labs and Shops ([https://www.ucop.edu/risk-services/\\_files/safety-resources/minors-in-labs-and-shops.pdf](https://www.ucop.edu/risk-services/_files/safety-resources/minors-in-labs-and-shops.pdf) and <https://www.physiology.ucla.edu/images/Safety/uc-minors-in-labs-shops-policy-impacts.pdf>)
- Promptly report all injuries, spills, releases of hazardous materials, and near-misses to EH&S

## Food/Drink:

- Do not eat, drink, smoke, chew gum, or apply cosmetics (including chapsticks) in areas where hazardous chemicals are handled or stored; wash hands before conducting these activities
- Do not store, handle, or consume food or beverages in storage areas, refrigerators, glassware or utensils which are also used for laboratory operations



- Wash areas of exposed skin well with soap and water before leaving the laboratory
- Do not put any objects (e.g., pencils, pens, fingers, swabs, etc.) in the mouth, ears, nose, etc. when working in a laboratory

### Mobile Devices:

- Never touch your mobile device when wearing gloves.
- Never place your mobile device on any laboratory surface that may be contaminated with chemicals.
- Mobile devices can act as an ignition source. Do not use a mobile device when handling flammable materials. Never use a mobile device when using the solvent systems.



# Chapter 5: Chemical Exposure Assessment

## Regulatory Requirements

Cal/OSHA requires that all employers “measure an employee’s exposure to any substance regulated by a standard which requires monitoring if there is reason to believe that exposure levels for that substance exceed the action level (or in the absence of an action level, the exposure limit).” Repeated monitoring may be required if initial monitoring identifies employee exposure over the action level or exposure limit. An employee has the right to request an evaluation from their employer to determine if an exposure assessment is needed.

Cal/OSHA regulates Permissible Exposure Limits (PELs) for airborne contaminants to which “nearly all workers may be exposed daily during a 40-hour workweek for a working lifetime (of 40 years) without adverse effect”, and are based upon an 8-hour Time-Weighted Average (TWA) exposure. Thus, the PELs are the maximum permitted 8-hour TWA concentration of an airborne contaminant without the use of respiratory protection. Cal/OSHA has also defined Short Term Exposure Limits (STELs) as the maximum TWA exposure during any 15 minute period, provided the daily PEL is not exceeded and Ceiling (C) exposures that shall not be exceeded at any time.

Cal/OSHA has listed established PELs, STELs, and Ceiling exposures for chemical contaminants identified in CCR Title 8 Section 5155 (Airborne Contaminants) Table AC-1 (<http://www.dir.ca.gov/Title8/ac1.pdf>). In the absence of a published Ceiling limit, Cal/OSHA requires employee exposure to concentrations above the PEL be controlled to prevent harmful effects. Further, Cal/OSHA has promulgated specific standards covering several regulated carcinogens, which may include an Action Level (AL), triggering medical surveillance requirements or the imposition of a specific Excursion Limit (such as for asbestos) with a unique measurement of the duration of an exposure.

Additionally, the Safe Drinking Water and Toxic Enforcement Act of 1986 requires Cal/EPA to publish annually a list of Proposition 65 chemicals known to the State to cause cancer or other reproductive toxicity (<https://oehha.ca.gov/media/downloads/proposition-65/p65list062819.pdf>).

## Exposure Assessment Overview

All UC employees require protection from exposure to hazardous chemicals above PELs, STELs and Ceiling concentrations. Cal/OSHA requires the person supervising, directing or evaluating the exposure assessment monitoring be competent in the practice of industrial hygiene. Thus, exposure assessment should be performed only by representatives of EH&S and not the PI/Laboratory Supervisor. General questions regarding exposure assessment or the Industrial Hygiene Program can be directed to EH&S, 4-6200.

Minimizing an exposure may be accomplished using a combination of engineering controls, administrative controls and personal protective equipment, listed in order of priority. Assessing exposure to hazardous chemicals may be accomplished through a number of methods performed by EH&S, including employee interviews, visual observation of chemical use, evaluation of engineering controls, use of direct reading instrumentation, or the collection of analytical samples from the employee’s breathing zone. Personal exposure assessment will be performed under either of the following situations:

1. Based on chemical inventories, review of Standard Operating Procedures (SOPs), types of engineering controls present, laboratory inspection results and/or review of the annual Laboratory Hazard Assessment Tool, EH&S determines whether an exposure assessment is warranted; or
2. User of a hazardous chemical has concern or reason to believe exposure is not minimized or eliminated through use of engineering controls or administrative practices (such as transfer of chemical through double needle performed entirely in a fume hood) and the potential for exposure exists. The user should then inform their PI/Laboratory Supervisor, who will in turn contact the EH&S Industrial Hygiene Program, EH&S Radiation Safety Division, or EH&S Injury Prevention Division. EH&S will then determine the best course of action in assessing employee exposure, including visual assessment, air monitoring, medical evaluation, examination, or medical surveillance.

In event of any serious injury or exposure, including chemical splash involving dermal or eye contact, immediately call **911** from a campus phone or cell phone and obtain medical treatment immediately. Do not wait for an exposure assessment to be performed before seeking medical care.

## **EXPOSURE ASSESSMENT PROTOCOL – NOTIFICATION TO EMPLOYEES OR EMPLOYEE REPRESENTATIVES AND RIGHT TO OBSERVE MONITORING (SECTION 340.1)**

The EH&S Industrial Hygiene Program conducts exposure assessments for members of the campus community. Employees have a right to observe testing, sampling, monitoring or measuring of employee exposure. They are also allowed access to the records and reports related to the exposure assessment. Exposure assessments may be performed for hazardous chemicals, as well as for physical hazards including noise and heat stress to determine if exposures are within PELs or other appropriate exposure limits that are considered safe for routine occupational exposure. General protocol in conducting an exposure assessment may include any of the following:

1. Employee interviews;
2. Visual observation of chemical usage and/or laboratory operations;
3. Evaluation of simultaneous exposure to multiple chemicals;
4. Evaluation of potential for absorption through the skin, mucus membranes or eyes;
5. Evaluation of existing engineering controls (such as measuring face velocity of a fume hood);
6. Use of direct reading instrumentation; and
7. Collection of analytical samples of concentrations of hazardous chemicals taken from the employees breathing zone, or noise dosimetry collected from an employee's shirt collar or various forms of radiation dosimetry.

If exposure monitoring determines an employee exposure to be over the action level (or the PEL) for a hazard for which OSHA has developed a specific standard (e.g., lead), the medical surveillance provisions of that standard shall be followed. It is the responsibility of the PI/Laboratory Supervisor to ensure that any necessary medical surveillance requirements are met. When necessary, EH&S will make recommendations regarding adjustments, engineering controls, or administrative procedures to maintain exposure below any applicable PEL. Where the use of respirators is necessary to maintain exposure below permissible exposure limits, UCI will provide, at no cost to the employee, the proper respiratory equipment and training. Respirators will be selected and used in accordance with the requirements of CCR Title 8 Section 5144 (<http://www.dir.ca.gov/Title8/5144.html>) and the University's Respiratory Protection Program.

In assessing exposure to hazardous chemicals for which Cal/OSHA has not published a PEL, STEL or Ceiling exposure, EH&S defers to the Threshold Limit Values (TLVs) established by the American Conference of Governmental Industrial Hygienists (ACGIH) or the Recommended Exposure Limits (RELs) established by the National Institute of Occupational Safety & Health (NIOSH). Please contact EH&S, 4-6200 for more information regarding these chemicals.

## **NOTIFICATION**

The Industrial Hygiene Program will promptly notify the employee and their PI/Laboratory Supervisor of the results in writing (within 15 working days or less if required) after the receipt of any monitoring results. The Industrial Hygiene Program will establish and maintain an accurate record of any measurements taken to monitor exposures for each employee. Records, including monitoring provided by qualified vendors, will be managed in accordance with CCR Title 8 Section 3204 "Access to Employee Exposure and Medical Records" (<http://www.dir.ca.gov/Title8/3204.html>).

## **EXPOSURE ASSESSMENT USE TO DETERMINE AND IMPLEMENT CONTROLS**

EH&S will use any of the following criteria to determine required control measures to reduce employee's occupational exposure:

1. Verbal information obtained from employees regarding chemical usage;
2. Visual observations of chemical use or laboratory operations;
3. Evaluation of existing engineering control measures or administrative practices;
4. Recommendations expressed in Safety Data Sheets;
5. Regulatory requirements of Cal/OSHA;
6. Recommendations from professional industrial hygiene organizations;
7. Direct reading instrumentation results;
8. Employee exposure monitoring results; and/or
9. Medical evaluation, examination and/or surveillance findings.

Particular attention shall be given to the selection of safety control measures for chemicals that are known to be extremely hazardous. Per Cal/OSHA CCR Title 8 Section 5141 "Control of Harmful Exposure to Employees" (<http://www.dir.ca.gov/Title8/5141.html>), the control of harmful exposures shall be prevented by implementation of control measures in the following order:

1. Elimination
2. Substitution
3. Engineering controls, whenever feasible;
4. Administrative controls whenever engineering controls are not feasible or do not achieve full compliance and administrative controls are practical; and
5. Personal protective equipment, including respiratory protection, during:
  - a. the time period necessary to install or implement feasible engineering controls
  - b. when engineering and administrative controls fail to achieve full compliance
  - c. in emergencies
  - d. as an extra precaution/option for employees

## Medical Evaluation

All employees, student workers, medical health services volunteers, or laboratory personnel who work with hazardous chemicals shall have an opportunity to receive a free medical evaluation, including supplemental examinations which the evaluating physician determines necessary, under the following circumstances:

1. Whenever an employee develops signs or symptoms associated with a hazardous chemical to which an employee may have been exposed in a laboratory;
2. Where personal monitoring indicates exposure to a hazardous chemical is above a Cal/OSHA Action Level (AL) or Permissible Exposure Limit (PEL) or recommended exposure levels established by the National Institute for Occupational Safety & Health (NIOSH) or the American Conference of Governmental Industrial Hygienists (ACGIH) in the event Cal/OSHA has not established an AL or PEL for a particular hazardous chemical;
3. Whenever an uncontrolled event takes place in the work area such as a spill, leak, explosion, fire, etc., resulting in the likelihood of exposure to a hazardous chemical; or
4. Upon reasonable request of the employee to discuss medical issues and health concerns regarding work-related exposure to hazardous chemicals.

All work-related medical evaluations and examinations will be performed by licensed physicians or staff under the direct supervision of a licensed physician. Evaluations and examinations will be provided without cost to the employee, without loss of pay, and at a reasonable time and place.

Any laboratory employee or student worker who exhibits signs and symptoms of adverse health effects from work-related exposure to a hazardous chemical should report immediately for a medical evaluation.

Refer to UCI's Injury & Illness Prevention Program (IIPP), for procedures on how to obtain medical evaluation under the above-listed circumstances (<http://www.ehs.uci.edu/programs/iipp/hsprog.html>).

### Information to Provide to the Clinician

At the time of the medical evaluation, the following information shall be provided to the examining physician:

1. Personal information such as age, weight and campus employee ID number;
2. Common and/or IUPAC name of the hazardous chemicals to which the individual may have been exposed;
3. A description of the conditions under which the exposure occurred;
4. Quantitative exposure data, if available;
5. A description of the signs and symptoms of exposure that the employee is experiencing, if any;
6. A copy of the Safety Data Sheet (SDS) of the hazardous chemical in question;
7. History of exposure including previous employment and non-occupational (recreational) hobbies; and
8. Any additional information helpful in assessing or treating an exposure or injury such as a biological component of exposure or existence of an antitoxin.





## Physician's Written Opinion

For evaluation or examinations required by Cal/OSHA, the employer shall receive a written opinion from the examining physician which shall include the following:

1. Recommendation for further medical follow-up;
2. Results of the medical examination and any associated tests, if requested by the employee;
3. Any medical condition which may be revealed in the course of the examination which may place the employee at increased risk as a result of exposure to a hazardous chemical found in the workplace; and
4. A statement that the employee has been informed by the physician of the results of the consultation or medical examination and any medical condition that may require further examination or treatment.

## Confidentiality & Individual's Access to Personal Medical Records

All patient medical information is protected by California and federal law and is considered strictly confidential. The examining physician is prohibited from disclosing any patient medical information that is not directly related to the work-related exposure under evaluation and should not reveal any diagnosis unrelated to exposure. Any patient information disclosed by the examining physician to the employee's supervisor will be limited to information necessary in assessing an employee's return to work, including recommended restrictions in work activities, if any. Any patient information disclosed by the examining physician to EH&S will be limited to information necessary to develop a course of exposure monitoring, or perform hazard assessments and incident investigations, if appropriate. The examining physician will otherwise disclose patient medical information only as required by California and Federal law, such as for Worker's Compensation Insurance claims. Each employee has the right to access their own personal medical and exposure records. The examining physician will provide an employee with a copy of their medical records upon written request.

## Medical Surveillance

Medical surveillance is the process of using medical examinations, questionnaires and/or biological monitoring to determine potential changes in health as a result of exposure to a hazardous chemical or other hazards. Certain Cal/OSHA standards require clinical examination as part of medical surveillance when exposure monitoring exceeds an established Action Level or PEL.

Outside vendors may provide medical surveillance services. Medical surveillance is required of employees who are routinely exposed to certain hazards as part of their job description (such as asbestos) and may be offered to other employees based upon quantifiable or measured exposure. Examples of hazards that are monitored through the medical surveillance program may include and not limited to:

- o Asbestos
- o Beryllium
- o Formaldehyde
- o Lead
- o Methylene Chloride
- o Noise (Hearing Conservation Program)
- o Radioactive Chemicals (Bioassay Program)
- o Respirator Use (Respirator Protection Program)
- o Other Particularly Hazardous Substances

Individuals with questions regarding work-related medical surveillance are encouraged to contact EH&S at 4-6200 for more information.

# Chapter 6: Inventory, Labeling, Storage, and Transport

## Regulatory Requirements

Implementation of the necessary work practices, procedures, and policies outlined in this chapter is required by the following:

- *Title 8, California Code of Regulations (CCR), Section 5164, "Storage of Hazardous Materials"* (<http://www.dir.ca.gov/title8/5164.html>)
- *Title 8, California Code of Regulations (CCR), Section 5191, "Occupational Exposures to Hazardous Chemicals in Laboratories"* (<http://www.dir.ca.gov/title8/5191.html>)
- *Title 8, California Code of Regulations (CCR), Section 5194, "Hazard Communication"* ([http://wp.sbcounty.gov/dbh/wp-content/uploads/2016/12/california\\_code\\_of\\_regulations-title8\\_section-5194\\_hazard\\_communication.pdf](http://wp.sbcounty.gov/dbh/wp-content/uploads/2016/12/california_code_of_regulations-title8_section-5194_hazard_communication.pdf))
- *Title 8, CCR, Section 5209, "Carcinogens"* (<http://www.dir.ca.gov/title8/5209.html>)
- *Title 8, CCR, Section 5154.1, "Ventilation Requirements for Laboratory-Type Hood Operations"* ([http://www.dir.ca.gov/title8/5154\\_1.html](http://www.dir.ca.gov/title8/5154_1.html))
- Assembly Bill 2286  
([https://leginfo.legislature.ca.gov/faces/billTextClient.xhtml?bill\\_id=201720180AB2286](https://leginfo.legislature.ca.gov/faces/billTextClient.xhtml?bill_id=201720180AB2286))

Other applicable regulations include those promulgated by the U.S. Department of Labor including 29 CFR 1910.1450 "Occupational Exposure to Hazardous Chemicals in Laboratories" (the "Laboratory Standard").

## Chemical Inventories

Each laboratory group is required to maintain a current chemical inventory that lists the chemicals and compressed gases used and stored in the labs and the quantity of these chemicals. Specific storage locations must be kept as part of the inventory list to ensure that they can be easily located. Chemical inventories are used to ensure compliance with storage limits and fire regulations and can be used in an emergency to identify potential hazards for emergency response operations.

The chemical inventory list should be reviewed prior to ordering new chemicals and only the minimum quantities of chemicals necessary for the research should be purchased. As new chemicals are added to the inventory, each laboratory group must confirm that they have access to the Safety Data Sheet (SDS) for that chemical. Where practical, each chemical should be dated so that expired chemicals can be easily identified for disposal. Inventory the materials in your laboratory frequently (at least annually) to avoid overcrowding with materials that are no longer useful and note the items that should be replaced, have deteriorated, or show container deterioration. Unneeded items should be returned to the storeroom/stockroom and compromised items should be discarded as chemical waste.

Indications for disposal include:

- Cloudiness in liquids

- Color change
- Evidence of liquids in solids, or solids in liquids
- "Puddling" of material around outside of containers
- Pressure build-up within containers
- Obvious deterioration of containers

Access to hazardous chemicals, including toxic and corrosive substances, should be restricted at all times. These materials must be stored in laboratories or storerooms that are kept locked when laboratory personnel are not present. Locked storage cabinets or other precautions are always recommended, and in some cases may be required in the case of controlled substances. For guidance on locked storage requirements, please contact EH&S, 4-6200.

On termination or transfer of laboratory personnel, all related hazardous materials should be properly disposed of, or transferred to the laboratory supervisor or a designee.

To facilitate improved inventory management and reporting, UCI is currently using a Chemical Inventory program called CiBR-Trac. However, the University of California, by order of the University of California Office of the President (UCOP), is in the process of switching to a new inventory system, UC Chemicals (<https://ehs.ucop.edu/chemicals/>). UC Chemicals provides immediate access to safety information, including the risks and hazards for every chemical logged into the system. This information should aid in inventory management, storage, and use of hazardous materials. Within the next couple years the entire UCI campus will be exclusively using UC Chemicals.

This program will allow UCI to more easily comply with both long standing and new regulation requiring chemical inventory maintenance and reporting. Cal/OSHA Title 8 Section 5194 (e) (1) requires that employers develop and maintain a list of the hazardous chemicals known to be present in the workplace. This is a long standing regulatory requirement and is an important component of our lab safety inspections. New regulation in the form of Assembly Bill 2286 mandates the development of the California Environmental Reporting System (CERS) and requires all regulated businesses to use the Internet to electronically submit chemical inventories.

In order to facilitate compliance with the new electronic reporting requirement, each lab group is required to maintain an up-to-date chemical inventory. Each group should update their inventory every time a chemical is added or removed from the inventory. The new chemical should be added to the inventory system the same day it is added to the laboratory. Each group is required to conduct a complete inventory reconciliation of their spaces at least once a year. Questions or comments regarding the Chemical Inventory program should be directed to the chemical hygiene officer **mdumas@uci.edu**. Technical questions about UC Chemicals should be directed to Risk and Safety Solutions, the developers of the program, [service@RiskandSafetySolutions.com](mailto:service@RiskandSafetySolutions.com).

## Chemical Labeling

Every chemical found in the laboratory must be properly labeled. Most chemicals come with a manufacturer's label that contains the necessary information, so care should be taken to not damage or remove these labels. Each chemical bottle, including diluted chemical solutions, must be labeled with its contents and the hazards associated with this chemical. It is recommended that each bottle also be dated when received and when opened to assist in determining which chemicals are expired and require disposal. When new chemicals and compounds are generated by laboratory operations, these new chemical bottles must be labeled with the name of the chemical or compound, date of generation, hazard information and the name of the generator or other party responsible for this chemical so that they may be contacted if questions arise about the container's contents.

Peroxide forming chemicals (e.g., ethers) (Appendix F) must be labeled with the date the chemical was received and the date the bottle was first opened. The amount of time these chemicals can be stored is dependent on their classification which ranges from Class A to Class C, Table 6.1. Do not store chemicals past their discard date and make sure a regular peroxide testing regiment is followed.

**Table 6.1 – Peroxide Forming Chemicals**

Classification	Conditions for Peroxide Formation	Discard/Testing Timeline	Examples
Class A	Form explosive levels of peroxides without concentration. These are the most hazardous and can form explosive peroxide levels even if not opened.	Test for peroxide formation or discard after 3 months of receiving the chemicals.	isopropyl ether, sodium amide, and potassium metal
Class B	Form explosive levels of peroxides upon concentration through distillation, evaporation or exposure to air after opening.	Test for peroxide formation or discard after 12 months.	tetrahydrofuran, vinyl ethers, glyme, 1,4-dioxane, and diethyl ether
Class C	Peroxide formation occurs due to self-polymerization. Storage in the liquid state drastically increases the potential formation of peroxides	Test for peroxide formation or discard after 12 months.	styrene, tetrafluoroethylene, butadiene, and vinyl acetate

These chemicals can degrade to form heat sensitive, shock sensitive, highly reactive compounds and should be stored and labeled very carefully. If you find a suspicious container, DO NOT move it or try to dispose of it on your own, notify coworkers and contact EH&S, 4-6200, immediately.

Particularly Hazardous Substances (see *Chapter 3*) require additional labeling to identify the specific hazard associated with each of these chemicals (carcinogen, reproductive toxin, acutely toxicant). In addition, the storage area where they are kept must be labeled with the type of hazard. These chemicals should be segregated from less hazardous chemicals to help with proper access control and hazard identification.

## Chemical Storage & Segregation

**Establish and follow safe chemical storage & segregation procedures for your laboratory.**

Storage guidelines are included for materials that are flammable, oxidizers, corrosive, water-reactive, explosive and highly toxic. The specific Safety Data Sheet (SDS) should always be consulted when doubts arise concerning chemical properties and associated hazards. All procedures employed must comply with Cal/OSHA, Fire Code and building code regulations. Always wear appropriate personal protective equipment (e.g., laboratory coat, safety glasses, gloves, safety goggles, apron, etc.) when handling hazardous chemicals. Be aware of the locations of the safety showers and emergency eyewash stations. Each laboratory is required to provide appropriate laboratory-specific training on

how to use this equipment and conduct lab specific training on the use/storage of hazardous chemicals **prior** to working with hazardous chemicals. Table 6.2 lists chemical safety storage priorities.

**Table 6.2 – Chemical Safety Storage Priorities**

Keep in mind that most chemicals have multiple hazards and a decision must be made as to which storage area would be most appropriate for each specific chemical. First, you have to determine your priorities:

1. **Flammability.** When establishing a storage scheme, the number one consideration should be the flammability characteristics of the material. If the material is flammable, it should be stored in a flammable cabinet or refrigerator designed for flammable storage.
2. **Isolate.** If the material will contribute significantly to a fire (e.g., oxidizers), it should be isolated from the flammables. If there were a fire in the laboratory and response to the fire with water would exaggerate the situation, isolate the water reactive material away from contact with water.
3. **Corrosivity.** Next look at the corrosivity of the material, and store accordingly.
4. **Toxicity.** Finally, consider the toxicity of the material, with particular attention paid to regulated materials. In some cases, this may mean that certain chemicals will be isolated within a storage area. For example, a material that is an extreme poison but is also flammable, should be locked inside a containment area in the flammable storage cabinet to protect it against accidental release.

There will always be some chemicals that will not fit neatly in one category or another, but with careful consideration of the hazards involved, most of these cases can be handled in a reasonable fashion.

## **GENERAL RECOMMENDATIONS FOR SAFE STORAGE AND SEGREGATION OF CHEMICALS**

Each chemical in the laboratory must be stored in a specific location and returned there after each use. Acceptable chemical storage locations may include corrosive cabinets, flammable cabinets, laboratory shelves, or appropriate refrigerators or freezers designed for the storage of hazardous chemicals. Fume hoods should not be used as general storage areas for chemicals, as this will seriously impair the ventilating capacity of the hood. Chemicals should not be routinely stored on bench tops or stored on the floor. Chemicals should be returned to their appropriate storage containers when not in use. Additionally, bulk quantities of chemicals (i.e., larger than one-gallon) should be stored in a separate storage area, such as a stockroom or supply room.

Laboratory shelves should have a raised lip along the outer edge to prevent containers from falling. Hazardous liquids or corrosive chemicals should not be stored on shelves above eye-level and chemicals which are highly toxic or corrosive should be in unbreakable secondary containers.

Chemicals must be stored at an appropriate temperature and humidity level and should **never** be stored in direct sunlight or near heat sources, such as laboratory ovens. Incompatible materials should be stored in separate cabinets, whenever possible. If these chemicals must be stored in one cabinet, due to space limitations, adequate segregation and secondary containment must be ensured to prevent adverse reactions. All stored containers and research samples must be appropriately labeled and tightly capped to prevent vapor interactions and to alleviate possible inhalation hazards. Flasks with cork, rubber or glass stoppers should be avoided because of the potential for leaking.

Laboratory refrigerators and freezers must be labeled appropriately with “No Food/Drink” and must **never** be used for the storage of consumable materials. Freezers should be defrosted periodically

so that chemicals do not become trapped in ice formations. **Never** store opened peroxide formers (e.g., ether) in a refrigerator or freezer! In regards to segregation of chemicals, three comprehensive tables were created in order to assist researchers with specific chemical incompatibilities. These tables can be found in Appendix H.

## FLAMMABLE AND COMBUSTIBLE LIQUIDS

Flammables should not be stored alongside combustible materials like paper and packaging nylon bags. Large quantities of flammable or combustible chemicals should not be stored in the laboratory. The maximum total quantity of flammable and combustible liquids must not exceed **60 gallons** within a flammable storage cabinet. The maximum quantity allowed to be kept outside a flammable storage cabinet, safety can, or approved refrigerator/freezer is **10 gallons per room**. The maximum total quantity of flammable and combustible liquids allowed in one fire control area is **120 gallons** this includes flammables kept within a flame cabinet. Only the amounts needed for the current procedure should be kept on bench tops or fume hoods and the remainder should be kept in flammable storage cabinets, explosion-proof refrigerators/freezers that are approved for the storage of flammable substances, or approved safety cans or drums that are grounded. Always segregate flammable or combustible liquids from oxidizing acids and oxidizers. Flammable materials must **never** be stored in domestic-type refrigerators/freezers and should not be stored in a refrigerator/freezer if the chemical has a flash point below the temperature of the equipment. Flammable or combustible liquids must not be stored on the floor or in any exit access.



Handle flammable and combustible substances only in areas free of ignition sources and use the chemical in a fume hood whenever practical. Only the amount of material required for the experiment or procedure should be stored in the work area. Always transfer flammable and combustible chemicals from glass containers to glassware or from glass container/glassware to plastic. Transferring these types of chemicals between metal containers may lead to a fire hazard due to static electricity. If you must transfer a Class 1A flammable chemical (e.g., diethyl ether, pentane) from a metal container make sure that the equipment is bonded and grounded.

## PYROPHORIC & WATER REACTIVE SUBSTANCES

Because pyrophoric substances can spontaneously ignite on contact with air and/or water, they must be handled under an inert atmosphere and in such a way that rigorously excludes air and moisture. Some pyrophoric materials are also toxic and many are dissolved or immersed in a flammable solvent. Other common hazards include corrosivity, teratogenicity, or peroxide formation.



Only minimal amounts of reactive chemicals should be used in experiments or stored in the laboratory. These chemicals must be stored as recommended in the SDS. Reactive materials containers must be clearly labeled with the correct chemical name, in English, along with a hazard warning.

Suitable storage locations may include inert gas-filled desiccators or glove boxes; however, some pyrophoric materials must be stored in a flammable substance approved freezer. If pyrophoric or water reactive reagents are received in a specially designed shipping, storage or dispensing container (such as the Aldrich Sure/Seal packaging system), ensure that the integrity of that container is maintained. Ensure that sufficient protective solvent, oil, kerosene, or inert gas remains in the container while pyrophoric materials are stored. Never store reactive chemicals with flammable materials or in a flammable liquids storage cabinet.

Storage of pyrophoric gases is described in the California Fire Code, Chapter 64 (<https://www.citymb.info/Home/ShowDocument?id=28089>). Gas cabinets, with remote sensors and fire suppression equipment, are required. Gas flow, purge and exhaust systems should have redundant controls to prevent pyrophoric gas from igniting or exploding. Emergency back-up power should be provided for all electrical controls, alarms and safeguards associated with the pyrophoric gas storage and process systems.

**Never** return excess reactive chemical to the original container. Small amounts of impurities introduced into the container may cause a fire or explosion. For storage of excess chemical, prepare a storage vessel in the following manner:

1. Dry any new empty containers thoroughly;
2. Insert the septum into the neck in a way that prevents atmosphere from entering the clean dry (or reagent filled) flask;
3. Insert a needle to vent the flask and quickly inject inert gas through a second needle to maintain a blanket of dry inert gas above the reagent;
4. Once the vessel is fully purged with inert gas, remove the vent needle then the gas line. To introduce the excess chemical, use the procedure described in the handling section, below;
5. For long-term storage, the septum should be secured with a copper wire;
6. For extra protection a second same-sized septa (sans holes) can be placed over the first; and
7. Use parafilm around the outer septa and remove the parafilm and outer septum before accessing the reagent through the primary septum.

The EH&S document titled *“Safe use of Pyrophoric Reagents”* (Appendix G) and Safety video at [http://www.ehs.uci.edu/programs/sop\\_library/Pyrophoric/Pyrophorics\\_combined\\_works.html](http://www.ehs.uci.edu/programs/sop_library/Pyrophoric/Pyrophorics_combined_works.html) provide information about the safe handling of pyrophoric chemicals.

## OXIDIZERS

Oxidizers (e.g., hydrogen peroxide, ferric chloride, potassium dichromate, sodium nitrate) are substances that cause or contribute to combustion of other materials. They should be stored in a cool, dry place and kept away from flammable and combustible materials ( e.g., wood, paper, Styrofoam, plastics, flammable organic chemicals), and away from reducing agents (e.g., zinc, alkaline metals, and formic acid).



## PEROXIDE FORMING CHEMICALS

Peroxide forming chemicals (e.g., diethyl ether, cyclohexene, tetrahydrofuran) should be stored in airtight containers in a dark, cool, and dry place and must be segregated from other classes of chemicals that could create a serious hazard to life or property should an accident occur (e.g., acids, bases, oxidizers). The containers should be labeled with the date received and the date opened. This information, along with the chemical identity should face forward to minimize container handling during inspection. These chemicals should also be tested and documented for the presence of peroxides on a timeline according to their classification, Table 6.1. Minimize the quantity of peroxide forming chemicals stored in the laboratory and dispose of peroxide forming chemicals before peroxide formation. Refer to Appendix F for specific guidelines and/or contact EH&S, 4-6200 with questions.

Carefully review all cautionary material supplied by the manufacturer prior to use. Avoid evaporation or distillation, as distillation defeats the stabilizer added to the solvents. Ensure that containers are tightly sealed to avoid evaporation and that they are free of exterior contamination or crystallization. **Never** return unused quantities back to the original container, contamination can cause the formation of peroxides. Make sure to clean all spills immediately.

If old containers of peroxide forming chemicals are discovered in the laboratory, (greater than two years past the expiration date, if the date of the container is unknown, or if you do not feel comfortable handling the container), **do not handle and/or touch the container**. If crystallization is present in or on the exterior of a container, **do not handle and/or touch the container**. These circumstances indicate the presence of peroxides which are heat, shock, and friction sensitive, even moving the container can lead to a high energy reaction. Secure the bottle, inform lab members not to touch the bottle, and contact EH&S, 4-6200, immediately for pick-up and disposal.

## CORROSIVES

Store corrosive chemicals (e.g., acids, bases) below shoulder level and in secondary containers that are large enough to contain at least 10% of the total volume of liquid stored or the volume of the largest container, whichever is greater. Acids must always be segregated from bases and from active metals (e.g., sodium, potassium, magnesium) at all times and must also be segregated from chemicals which could generate toxic gases upon contact (e.g., sodium cyanide, iron sulfide).



Specific types of acids require additional segregation. Organic acids should be segregated from inorganic acids (mineral acids). Oxidizing acids must be segregated from organic compounds including organic acids, flammable and combustible substances. Perchloric acid and hydrofluoric acid should be stored by themselves, away from all other chemicals. Picric Acid is reactive with metals or metal salts and explosive when dry and must contain at least 10% water to inhibit explosion. Perchloric acid that is heated must be used in a specific fume hood to prevent formation of explosive powder residue, if your lab plans to use perchloric acid inform EH&S, 4-6200, immediately.

## SPECIAL STORAGE REQUIREMENTS

### Compressed Gases and Toxic Gases



Compressed gas cylinders that are stored in the laboratory must be chained to the wall or cylinder storage rack, with the safety cap in place. The cylinders must be restrained by two chains at all times; one chain must be placed at one third from the top of the cylinder, and the other placed at one third from the bottom of the cylinder (see Figure 6.1). No more than three cylinders may be chained together with one chain. Bolted “clam shells” may be used in instances where gas cylinders must be stored or used away from the wall. Store gas cylinders securely in the upright position. **Cylinders containing certain gases are**

Figure 6.1 – Cylinders Stored and Chained Correctly

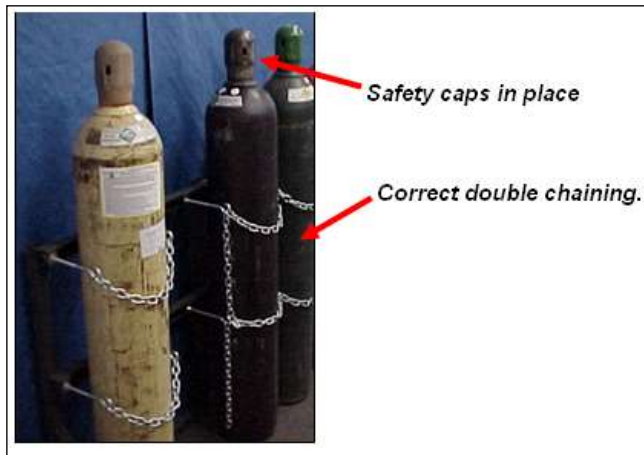



**prohibited from being stored in a horizontal position, including those which contain liquefied fuel or a water volume of more than 5 liters.** Do not expose cylinders to excessive dampness, corrosive chemicals or fumes.

Certain gas cylinders require additional precautions. Flammable gas cylinders must use only flame-resistant gas lines and hoses which carry flammable or toxic gases from cylinders and must have all connections wired. Compressed oxygen gas cylinders must be stored at least 20 feet away from combustible materials and flammable gases.

Gas cylinder connections must be inspected frequently for deterioration and must never be used without a regulator. Never use a leaking, corroded or damaged cylinder. Never refill compressed gas cylinders. When stopping a leak between the cylinder and regulator, always close the valve before tightening the union nut. The regulator must be replaced with a safety cap when the cylinder is not in use. When moving gas cylinders, verify first that the safety cap is in place and only use carts designed for this purpose. Please refer to the UCI Compressed Gases Safety Program (<https://www.ehs.uci.edu/programs/safety/compressedgasprog.pdf>) for more details.

Due to potential health, fire and reactivity hazards presented by the potential release of toxic gases, the UCI **Toxic Gas Program** has been written to indicate the special regulatory requirements mandated for these gases by the Fire Code, Cal/OSHA and other regulatory agencies. The program specifies safe and established procedures for the transportation, handling, storage, use, and disposal of toxic gases along with required engineering and administrative controls that reduce the likelihood of an unintended release. One additional topic of emphasis for toxic gas usage is emergency response procedures for their accidental release. As a result, labs are expected to devise an emergency response plan that suites their precautionary level and communicate it through training of all users and non-users. For more details and a list of toxic gases see the Appendix Table of the program that can be found at <https://www.ehs.uci.edu/programs/labres/ToxicGP.pdf>.

## Liquid Nitrogen



Because liquid nitrogen containers are at low pressure and have protective rings mounted around the regulator, they are not required to be affixed to a permanent fixture such as a wall. However, additional protection considerations should be addressed when storing liquid nitrogen in a laboratory. The primary risk to laboratory personnel from liquid nitrogen is skin or eye thermal damage caused by contact with the material. In addition, nitrogen expands 696:1 when changing from a cryogenic liquid to a room temperature gas. The gases usually are not toxic, but if too much oxygen is displaced, asphyxiation is a possibility. Therefore, liquid nitrogen cylinders and tanks should be stored in an area with adequate ventilation.

If a large amount of liquid nitrogen is spilled, never clean it up yourself. Always use appropriate thermally insulated gloves when handling liquid nitrogen. Face shields may be needed in cases where splashing can occur.

## Laboratory Security

Recently regulatory agencies have been implementing rules to ensure chemical security. While many of these rules are for large manufacturing facilities, it is critical that chemicals be secured to prevent theft from campus laboratories. Numerous federal agencies are involved in the maintenance of laboratory security, including the Drug Enforcement Agency



([www.deadiversion.usdoj.gov/schedules](http://www.deadiversion.usdoj.gov/schedules)), Federal Bureau of Investigations ([www.fbi.gov/about-us/investigate/terrorism/wmd](http://www.fbi.gov/about-us/investigate/terrorism/wmd)), and Department of Homeland Security ([www.dhs.gov/xlibrary/assets/chemsec\\_appendixa-chemicalofinterestlist.pdf](http://www.dhs.gov/xlibrary/assets/chemsec_appendixa-chemicalofinterestlist.pdf)).

It is each laboratory's responsibility to prevent and report any theft of chemicals from their laboratory. Access to hazardous chemicals should be restricted at all times and must be stored in laboratories and storerooms that are locked when laboratory personnel are not present.

Laboratories are encouraged to conduct a Security Value Assessment (SVA). Aspects that should be covered in a SVA include:

- Existing threats, based on the history of the institution (e.g., theft of laboratory materials, sabotage, data security breaches, protests);
- The attractiveness of the institution as a target, and the potential impact of an incident;
- Chemicals, biological agents, radioactive materials, or other laboratory equipment or materials with dual-use potential
- Sensitive data or computerized systems;
- Animal care facilities;
- Infrastructure vulnerabilities (e.g., accessible power lines, poor lighting);
- Security systems in place (e.g., access control, cameras, intrusion detection);
- Access controls for laboratory personnel (e.g., background checks, authorization procedures, badges, key controls, escorted access);
- Institutional procedures and culture (e.g., tailgating, open laboratories, no questioning of visitors);
- Security plans in place; and
- Training and awareness of laboratory personnel.

Labs can increase their security by simply keeping lab doors closed and locked when unoccupied, maintaining a current and accurate chemical inventory, training personnel on security procedures, and controlling access to keys. Labs should report any suspicious activity to UCI Police at 4-5223 and UCI EH&S at 4-6200.

## On-Campus Distribution of Hazardous Chemicals

Precautions must be taken when transporting hazardous substances between laboratories and between buildings within the campus. Chemicals must be transported between stockrooms and laboratories in break-resistant, secondary containers such as commercially available bottle carriers made of rubber, metal, or plastic, that include carrying handle(s) and which are large enough to hold the contents of the chemical container in the event of breakage. In the case of big quantities or more than one chemicals being transported the appropriate cart with build-in secondary containment should be utilized and high traffic areas need to be avoided. Never use a secondary container that will react with or is incompatible with the chemical that is being transported.

When transporting cylinders of compressed gases, always secure the cylinder with straps or chains onto a suitable hand truck and protect the valve with a cover cap. Avoid dragging, sliding, or



Figure 6.2 – Correct Cylinder Transport

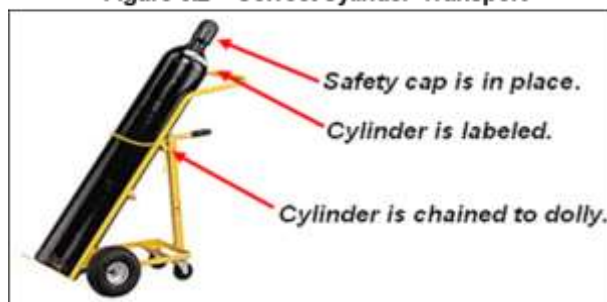

rolling cylinders and use a freight elevator when possible. Figure 6.2 illustrates correct cylinder transport.

## Off-Campus Distribution of Hazardous Chemicals

The transportation of hazardous chemicals and compressed gases over public roads, or by air, is strictly governed by international, federal, and state regulatory agencies, including the U.S. Department of Transportation (DOT) and the International Air Transport Association (IATA). Any person who prepares and/or ships these types of materials must ensure compliance with pertinent regulations regarding training, quantity, packaging, and labeling. **Without proper training, it is illegal to ship hazardous materials.** Those who violate the hazardous materials shipment regulations are subject to criminal investigation and penalties. UCI campus personnel who sign hazardous materials manifests, shipping papers, or those who package hazardous material for shipment, must be trained and certified by EH&S. Shipping and receiving chemicals internationally have additional regulations including the Toxic Substances Control Act (TSCA).

Individuals who wish to ship or transport hazardous chemicals or compressed gases off-campus, even when using UCI or personal vehicles, must contact EH&S, 4-6200 for assistance.

For more information regarding hazardous material shipping responsibilities, training requirements and FAQs, refer to <http://www.ehs.uci.edu/programs/dgoods/index.html>

# Chapter 7: Training

## Regulatory Requirements

Implementation of the necessary work practices, procedures, and policies outlined in this chapter is required by the following:

- *Title 8, California Code of Regulations (CCR), Section 5191, "Occupational Exposures to Hazardous Chemicals in Laboratories"* (<http://www.dir.ca.gov/title8/5191.html>)
- *Title 8, California Code of Regulations (CCR), Section 5194, "Hazard Communication"* (<http://www.dir.ca.gov/title8/5194.html>)
- *Title 8, CCR, Section 5209, "Carcinogens"* (<http://www.dir.ca.gov/title8/5209.html>)

Other applicable regulations include those promulgated by the U.S. Department of Labor including 29 CFR 1910.1450 "Occupational Exposure to Hazardous Chemicals in Laboratories" (the "Laboratory Standard").

## Introduction

Effective training is critical to facilitate a safe and healthy work environment and prevent laboratory accidents. All PIs/Laboratory Supervisors must participate in formal safety training and ensure that all their employees have appropriate safety training before working in a laboratory. EH&S provides both classroom and online training to help meet this requirement on the UC Learning Center website at <http://www.uclc.uci.edu/>.

PIs/Laboratory Supervisors must provide laboratory specific safety training including standard operating procedures (SOPs) for each chemical band (e.g., toxics, corrosives), regulated carcinogens (e.g., benzene, formaldehyde, cadmium), and high hazard processes. EH&S provides templates for a variety of SOPs, however every PI/Laboratory Supervisor must provide laboratory specific procedures and details to the SOP for it to be complete. Every lab should have a laboratory safety binder which contains all of the SOPs for the lab. All laboratory personal, including the PI/Laboratory Supervisor, must sign every SOP within the laboratory binder after reading and understanding the SOP. PIs/Laboratory Supervisors are encouraged to provide additional training for all laboratory personal who will be working within their laboratory. Additional training will provide laboratory personal with a greater understanding of the specific hazards associated with their working environment.

## Types of Training

All laboratory personnel must complete general laboratory safety training and lab specific training before:

1. Beginning work in the laboratory;
2. Prior to new exposure situations; and
3. As work conditions change.

Refresher training is also required for all laboratory personnel. EH&S offers general classroom and online training, plus resource materials to assist laboratories in implementing laboratory-specific training.

## GENERAL LABORATORY SAFETY TRAINING

Anyone working in a laboratory is required to complete laboratory safety training, which includes:

- Review of laboratory rules and regulations, including the Chemical Hygiene Plan
- Recognition of laboratory hazards (LHAT, <https://ehs.ucop.edu/lhat/>)
- Use of engineering controls, administrative controls and personal protective equipment to mitigate hazards
- Exposure limits for hazardous chemicals
- Signs and symptoms associated with exposures to hazardous chemicals
- Chemical exposure monitoring
- Review of reference materials (e.g., SDS) on hazards, handling, storage and disposal of hazardous chemicals
- Procedures for disposing of hazardous chemical waste
- Fire safety and emergency procedures
- Information required by Section 3204 (<https://www.dir.ca.gov/title8/3204.html>) regarding access to employee exposure and medical records (annually required)

All employees must attend the following basic laboratory safety classes provided by EH&S as appropriate for their employment status:

- **UC Laboratory Safety Fundamentals** – for anyone working in a laboratory (refresher course every three years)
- **Hazardous waste** – for anyone working in a laboratory creating waste (biological, chemical, radiological)
- **Hazardous Materials Incidents Emergency Procedures Training** – all staff, students and faculty handling hazardous materials (chemical, biohazardous, radioactive) must complete an annual emergency procedures training

Safety training requirements are determined by completing the Safety Training Self-Assessment described at <http://www.ehs.uci.edu/SafetyTrainingSelf-AssessmentInstructions.pdf>. Log into the UC Learning Center to complete your self-assessment at <http://www.uclc.uci.edu/>.

## LABORATORY-SPECIFIC TRAINING

PIs/Laboratory Supervisors must provide laboratory-specific training to their employees prior to working in the laboratory. Topics that require specific training include but are not limited to:

- Location and use of the Chemical Hygiene Plan, Injury and Illness Prevention Program (IIPP), SDS(s) and other regulatory information
- Review of IIPP and Emergency Management Plan, including location of emergency equipment and exit routes
- Proper use and when to use engineering controls, administrative controls, and personal protective equipment to mitigate hazards

- Review of reference materials and how to find reference materials on hazards, handling, storage, and disposal of hazardous chemicals
- Specialized equipment
- Standard Operating Procedures (SOPs)
- Specialized procedures and protocols
- Particularly Hazardous Substances including physical and health hazards, potential exposure, medical surveillance, and emergency procedures
- It is a University of California policy that each person working in a laboratory or technical area receives a one-time site specific orientation (<http://www.ehs.uci.edu/programs/labres/LaboratorySiteSafetyOrientationChecklist.docx>)
- Lab-specific training is recommended to be provided on a regular basis to promote a strong safety culture

## Resources

EH&S has a number of tools available for laboratories to simplify the completion of appropriate training, including but not limited to the following:

- Online training modules (<http://www.uclcl.uci.edu/>). Completing the Training Self-Assessment will provide a complete list of available training courses.
  - **UC Laboratory Safety Fundamentals**
  - Bloodborne Pathogens
  - Chemical Fume Hood
  - Fire Extinguisher Safety
  - Formaldehyde Safety
  - Hazard Communication
  - **Hazardous Waste**
  - **Hazardous Materials Incidents Emergency Procedures Training**
- Standard Operating Procedures ([http://www.ehs.uci.edu/programs/sop\\_library/index.html](http://www.ehs.uci.edu/programs/sop_library/index.html))
  - Chemical Specific SOPs
  - Banded SOPs
  - Process specific SOPs
  - Pyrophoric Reagents SOP and Pyrophoric Safety (Video)
- DVD Lending Library (<http://www.ehs.uci.edu/train.html>)
  - Chemical Hygiene/Laboratory Safety
  - Hazard Communication and General Safety
  - Respiratory Protection
  - Waste Management

EH&S provides additional assistance in planning laboratory-specific training upon request.

## Documentation of Training

Accurate recordkeeping is a critical component of health and safety training. Per OSHA regulations, departments or laboratories are responsible for documenting all health and safety training, including safety meetings, one-on-one training, and classroom and online training. Documentation should be maintained in the Laboratory Safety Binder.

The UC Learning Center website <http://www.uclcl.uci.edu/> documents training history for all courses completed online.

# Chapter 8: Inspections and Compliance

## Regulatory Requirements

Implementation of the necessary work practices, procedures, and policies outlined in this chapter is required by the following:

- *Title 8, California Code of Regulations (CCR), Section 5191, "Occupational Exposures to Hazardous Chemicals in Laboratories"* (<http://www.dir.ca.gov/title8/5191.html>)

Other applicable regulations include those promulgated by the U.S. Department of Labor including 29 CFR 1910.1450 "Occupational Exposure to Hazardous Chemicals in Laboratories" (the "Laboratory Standard").

## Laboratory Safety Inspections

EH&S has a comprehensive laboratory safety compliance program to assist laboratories and other facilities that use, handle or store hazardous chemicals to maintain a safe work environment. This program helps to ensure compliance with regulations and to fulfill UCI's commitment to protecting the health and safety of the campus community.

As part of this laboratory safety program, EH&S conducts periodic inspections of laboratories and other facilities with hazardous chemicals to ensure the laboratory is operating in a safe manner and to ensure compliance with all federal, state and university safety requirements. The primary goal of inspection is to identify both existing and potential accident-causing hazards, actions, faulty operations and procedures that can be corrected **before** an accident occurs. UCI policy (<http://www.policies.uci.edu/policies/pols/903-10.php>) authorizes EH&S to order the cessation of any activity that is "Immediately Dangerous to Life or Health" (IDLH) until that hazardous condition or activity is abated.

The laboratory safety inspection is comprehensive in nature and looks into all key aspects of working with hazardous chemicals. While inspections are a snapshot in time and cannot identify every accident-causing mistake, they do provide important information on the overall operation of a particular laboratory. They can also help to identify weaknesses that may require more systematic action across a broader spectrum of laboratories, and strengths that should be fostered in other laboratories. The complete inspection checklist can be found at <https://www.ehs.uci.edu/labres.html>.

Specific inspection compliance categories include:

1. Documentation and Training;
2. Hazard Communication (including review of SOPs);
3. Emergency and Safety Information;
4. Fire Safety;
5. General Safety;
6. Use of personal protective equipment (PPE);
7. Housekeeping;

8. Chemical Storage;
9. Fume Hoods;
10. Chemical Waste Disposal and Transport;
11. Seismic Safety; and
12. Mechanical and Electrical Safety.

Planned, focused assessments are also conducted. Examples of these include industrial hygiene assessments and unannounced PPE inspections. Once the inspection is completed, EH&S issues a Laboratory Inspection Report via email. The report identifies deficiencies in the laboratory, both critical and non-critical. Critical deficiencies are those that have the potential to lead to serious injuries or be of critical importance in the event of an emergency. These deficiencies must be immediately corrected, within 48-hours. Non-critical deficiencies must be corrected within 30-days. Any deficiency that requires a "Facilities Management Request" (FMR) for completion will be added to the FMR database so that it can be expedited by Facilities Management. A copy of the most recent *Laboratory Inspection Report* should be maintained as part of the records inside the **Laboratory Safety Binder**.

## **NOTIFICATION AND ACCOUNTABILITY**

The compliance program requires that PIs/Laboratory Supervisors and other responsible parties take appropriate and effective corrective action upon receipt of written notification of inspection findings. Critical deficiencies are required to be corrected within 48-hours; non-critical deficiencies must be corrected within 30-days. Failure to take corrective actions within the required timeframe will result to a repeat violation and a 45 day follow-up will be completed by the department coordinator who will intervene in order to mitigate the identified deficiencies.

## **RECORDKEEPING REQUIREMENTS**

Accurate recordkeeping demonstrates a commitment to the safety and health of the UC community, integrity of research, and protection of the environment. EH&S is responsible for maintaining records of inspections, accident investigations, equipment calibration, and training conducted by EH&S staff. Per OSHA regulations, departments, or laboratories must document health and safety training, including safety meetings, one-on-one training, classroom training and online training. Additionally, the following records must be retained in accordance with the requirements of state and federal regulations:

1. Accident records (5 years);
2. Laboratory Inspections records (5 years);
3. Training records (3 years);
4. Measurements taken to monitor employee exposures (30 years);
5. Chemical Hygiene Plan records should document that the facilities and precautions were compatible with current knowledge and regulations;
6. Inventory and usage records for high-risk substances should be kept;
7. Any medical consultation and examinations, including tests or written opinions required by CCR, Title 8, Section 5191 (duration of employment plus 30 years);
8. Medical records must be retained in accordance with the requirements of state and federal regulations (duration of employment plus 30 years).



# Chapter 9: Hazardous Chemical Waste Management

## Regulation of Hazardous Waste

In California, hazardous waste is regulated by the Department of Toxic Substance Control (DTSC), a division within the California Environmental Protection Agency (Cal/EPA). Federal EPA regulations also govern certain aspects of hazardous waste management, since most of our waste is treated and disposed out of state. These hazardous waste regulations are part of the Resource Conservation and Recovery Act, or RCRA. Local enforcement authority is administered by the Orange County Health Care Agency Environmental Health Division.

## Hazardous Waste Program

The EH&S Hazardous Waste Program manages the shipment and disposal of all hazardous waste generated on campus. Each laboratory employee must comply with the campus Hazardous Waste Management Program requirements (<http://www.ehs.uci.edu/programs/enviro/>) and all applicable regulations. Hazardous waste pick-up service is provided to all UCI hazardous waste generators. Laboratory personnel are responsible for identifying hazardous waste, segregating, labeling, and storing it properly in the laboratory. Laboratory clean-outs and disposal of high hazard compounds must be scheduled in advance. The PI/Laboratory Supervisor is responsible for coordinating the disposal of all chemicals from their laboratories prior to closing down laboratory operations.



## DEFINITION OF HAZARDOUS WASTE

Federal and State regulations define hazardous waste as a substance that poses a hazard to human health or the environment when improperly managed. A chemical waste is considered hazardous if it is either listed on one of the lists of hazardous wastes found in the Federal or State regulations, or exhibits one or more of the four characteristics listed below.

- **Ignitable**



- Flashpoint <140 °F
- Capable of causing fire at standard temperature and pressure through friction, absorption of moisture, or spontaneous chemical changes
- Is an ignitable compressed gas
- Is an oxidizer

- **Corrosive**



- Liquid with pH less than or equal to 2 or greater than or equal to 12.5
- Solid with pH less than or equal to 2 or greater than or equal to 12.5 when mixed with equal weight of water

- **Reactive**

- Normally unstable and readily undergoes violent change
- Reacts violently with water or air
- Forms potentially explosive mixtures with water
- Forms toxic gases, vapors or fumes when mixed with water
- Is a cyanide or sulfide bearing waste which, when exposed to pH conditions between 2 and 12.5, can generate toxic gases, vapors, or fumes
- Is capable of detonation or explosive decomposition if subjected to a strong initiating source or heated under confinement
- Is readily capable of detonation or reaction at standard temperature and pressure



- **Toxic**



- Has an acute oral LD50 less than 2,500 mg/kg
- Has an acute dermal LD50 less than 4,300 mg/kg
- Has an acute inhalation LC50 less than 10,000 ppm as a gas or vapor
- Has an acute aquatic 96-hour LC50 less than 500 mg/l
- Has been shown through experience or testing to pose a hazard to human health or environment because of its ability to cause cancer or mutations (carcinogen, mutagen, teratogen), acute toxicity, chronic toxicity, bio-accumulative properties, or persistence in the environment

The EPA definition of hazardous waste also extends to the following items:

- Abandoned chemicals
- Unused or unwanted chemicals
- Chemicals in deteriorating containers (e.g., broken caps, corroded, cracked bottle)
- Empty containers that have visible residues
- Containers with conflicting labels (never put more than one label on a bottle, if a container is going to be reused, completely remove the previous label before putting a new label on the container)
- Unlabeled or unknown chemicals

## **EXTREMELY HAZARDOUS WASTE**

Certain compounds meet an additional definition known as “extremely hazardous waste”. This list of compounds includes carcinogens, pesticides, and reactive compounds, among others (e.g., formaldehyde, chloroform, and hydrofluoric acid). The Federal EPA refers to this waste as “acutely hazardous waste”, but Cal/EPA has published a more detailed list of extremely hazardous waste. Both the State and the Federal lists are included in the EH&S list of extremely hazardous waste, found at: <http://www.ehs.uci.edu/programs/enviro/AcutelyExtremelyHazardousWaste.xls>. NOTE: While there is some overlap with the list of Particularly Hazardous Substances, such as the examples listed above, the extremely hazardous waste list is specific to the hazardous waste management program.

## **Proper Hazardous Waste Management**

### **TRAINING**

All personnel who are responsible for handling, managing, or disposing of hazardous waste must attend training **prior** to working with these materials. The EH&S online Hazardous Waste training course covers the hazardous waste program requirements and includes training on container labeling

(<http://www.ehs.uci.edu/programs/enviro/>). To complete Hazardous Waste training, log on to the UC Learning Center website at <http://www.uclc.uci.edu/>. Laboratory specific hazardous waste training should also be conducted prior to working with hazardous materials. Laboratory specific hazardous waste training should include information relevant to handling, managing, or disposing of the specific hazardous waste generated in the laboratory (e.g., waste streams generated in the laboratory, incompatible waste streams, and proper waste labeling).

## WASTE IDENTIFICATION

All the chemical constituents in each hazardous waste stream must be accurately identified by knowledgeable laboratory personnel. This is a critical safety issue for both laboratory employees and the waste technicians that handle the waste once it is turned over to EH&S. Mixing of incompatible waste streams has the potential to create violent reactions and is a common cause of laboratory accidents. DO NOT mix waste streams and never put incompatible materials in the same waste container. Always check the contents of a waste container before adding waste to the container. If there is uncertainty about the composition of a waste stream resulting from an experimental process, laboratory workers must consult the PI/Laboratory Supervisor, the Chemical Hygiene Officer, or the Hazardous Waste Manager. In most cases, careful documentation and review of all chemical products used in the experimental protocol will result in accurate waste stream characterization.

The manufacturer's SDS provides detailed information on each hazardous ingredient in laboratory reagents and other chemical products, and the chemical, physical, and toxicological properties of that ingredient. To avoid incompatible mixtures review the stability and reactivity section (section 10) in the SDS which contains a list of incompatible materials. The UC SDS library (<http://www.ucmsds.com>) provides an extensive library of research chemicals.

## LABELING

Hazardous waste labels must be placed on the hazardous waste container upon the start of accumulation. Labels are available online at [www.ehs.uci.edu/programs/enviro/](http://www.ehs.uci.edu/programs/enviro/). Each label must be completed accurately, and updated as the contents of the waste container change. Product names or abbreviations for waste container ingredients should not be used. If the label is damaged or illegible, immediately replace the label with a new clear and legible label.



Labels must be placed on the hazardous waste container upon the start of accumulation. Labels are available online at [www.ehs.uci.edu/programs/enviro/](http://www.ehs.uci.edu/programs/enviro/). Each label must be completed accurately, and updated as the contents of the waste container change. Product names or abbreviations for waste container ingredients should not be used. If the label is damaged or illegible, immediately replace the label with a new clear and legible label.

## STORAGE

The hazardous waste storage area in each laboratory is considered a Satellite Accumulation Area (SAA) by the EPA. According to EPA requirements, this area must remain under the control of the persons producing the waste. This means that it should be located in an area that is supervised and is not accessible to the public. Other SAA requirements include:

- Hazardous waste must be disposed of via EH&S within 6 months of being generated.



- Hazardous waste containers must be stored in secondary containment to adequately contain all of the contents of the container.
- Hazardous waste containers must be kept closed, except when adding waste.
- Hazardous waste that meets the quantity threshold of 55 gallons of hazardous waste or 1 quart of **acutely / extremely hazardous waste** must be disposed of within 3 days of reaching these set volumes.
- Report damaged containers to EH&S. EH&S can provide assistance to transfer the contents of the damaged container to an appropriate container.
- Containers must be inspected weekly for signs of leaks, corrosion, or deterioration.
- Do not dispose of chemicals by pouring them down the drain or placing them in the trash.
- Do not evaporate chemicals; always cap waste containers to prevent unintended evaporation.
- Hazardous waste streams must have compatible constituents, and must be compatible with the containers that they are stored in (e.g., do not use glass containers for hydrofluoric acid waste)
- Only add waste to a waste container inside a fume hood. Never open a waste container outside of the fume hood because it can lead to accidental exposure.
- Hazardous waste containers must be properly labeled at all times.
- Only fill hazardous waste containers to the fill line (~ ¾ full). Never overfill the waste containers.
- Do not recap needles before discarding. Recapping could lead to serious needle stick injuries and injection of hazardous materials. Discard used needles directly uncapped into the designated rigid sharps container. (It is good practices to label sharps waste containers with a note of caution stating “Do Not Recap Needles After Use, Discard Them Directly into the Sharps Waste Container”).
  - If you must reuse a needle, never leave an open needle around the laboratory. When possible use a cork ring or rubber stopper to plug the needle to prevent punctures



## SEGREGATION

All hazardous waste must be segregated to prevent incompatible mixtures. Proper segregation of waste is essential to avoid hazardous uncontrolled reactions.

Segregation should be by hazard class. Hazard class examples include: flammable, oxidizer, pyrophoric, reactive, reducer, inorganic acid, organic acid, base, and toxic.

Examples of proper segregation are:

- Segregate acids from bases
- Segregate oxidizers from organic compounds
- Segregate cyanides from acids
- Separate flammables from oxidizers

For more information on specific chemical incompatibility, consult a safety data sheet (SDS). Section 10, Stability and Reactivity has a list of incompatible materials.

## INCOMPATIBLE WASTE STREAMS

Mixing incompatible waste streams, or selecting a container that is not compatible with its contents, is a common cause of accidents in laboratories and waste storage facilities. Reactive mixtures can

rupture containers and explode, resulting in serious injury and property damage. All chemical constituents and their waste byproducts must be compatible for each waste container generated. Waste labels must be immediately updated when a new constituent is added to a mixed waste container, so that others in the laboratory will be aware and manage it accordingly. Never add to a waste if you do not know what its contents are. Never mix waste streams, always separate incompatibles.

Some common incompatible waste streams include:

- Oxidizers added to any fuel that can create an exothermic reaction and explode. The most frequent is acids oxidizing flammable liquids. For this reason, all flammable liquids are pH tested before they are consolidated.
- Piranha etch solution is a specific waste stream that contains sulfuric acid and hydrogen peroxide, which form a reactive mixture that is often still fuming during disposal. For this waste stream, and other reactive mixtures like it, vented caps are mandatory.

**Keep in mind that mixing incompatibles can lead to accidents and emergencies (e.g., exothermic reactions, explosion, and formation of toxic gases) so always avoid mixing incompatible materials.**

## **WASTES THAT REQUIRE SPECIAL HANDLING**

### **Unknowns**

Unlabeled chemical containers and unknown/unlabeled wastes are considered unknowns, and additional fees must be paid to have these materials analyzed and identified. These containers must be labeled with the word “unknown”. Never mix unknown materials for any reason! Inform EH&S immediately if you find an unknown container or waste bottle, they will pick it up and dispose of it properly.

### **Peroxide Forming Chemicals**

Peroxide forming chemicals, or PFCs, include a number of substances that can react with air, moisture or product impurities, and undergo a change in their chemical composition during normal storage. The peroxides that form are highly reactive and can explode upon friction, shock, or spark. Peroxides are not particularly volatile and thus tend to precipitate out of liquid solutions. It is particularly dangerous to allow a container of these materials to evaporate to dryness, leaving the crystals of peroxide on the surfaces of the container. Always keep containers of peroxide forming chemicals capped tightly and ensure that the cap/bottle are not degraded or broken.

Each container of peroxide forming chemicals should be dated with the date received and the date first opened. There are three classes of peroxide forming chemicals, with each class having different management guidelines. A guide to managing some PFCs commonly found in research labs is provided in Appendix F. Since this Appendix does not provide an exhaustive list of PFCs, review the safety information provided by the manufacturer for any chemicals you purchase.

Ensure containers of PFCs are kept tightly sealed to avoid unnecessary evaporation, as this inhibits the stabilizers that are sometimes added. Visually inspect containers periodically to ensure that they are free of exterior contamination or crystallization. PFC containers must be disposed of prior to their expiration date. If old containers of peroxide forming chemicals are discovered in the laboratory, (greater than two years past the expiration date or if the date of the container is unknown), **do not**

**handle/touch/move the container.** If crystallization, discoloration, contamination, or any observation that indicates decomposition is present in or on the exterior of a container, **do not handle/touch/move the container.** Even a small movement of a bottle containing peroxides can lead to an explosion. Secure it and contact EH&S, 4-6200 for pick-up and disposal.

### **Dry Picric Acid**

Picric acid (also known as trinitrophenol) must be kept hydrated with deionized water at all times, as it becomes increasingly unstable as it loses water content. When dehydrated, it is not only explosive but also sensitive to shock, heat and friction. Picric acid is highly reactive with a wide variety of compounds (including many metals) and is extremely susceptible to the formation of picrate salts. Be sure to label all containers that contain picric acid with the date received, and then monitor the water content every 6 months. Add deionized or distilled water as needed to maintain a consistent liquid volume.

If old or previously unaccounted for bottles of picric acid are discovered, **do not touch the container.** Depending on how long the bottle has been abandoned and the state of the product inside, even a minor disturbance could be dangerous. Visually inspect the contents of the bottle without moving it to evaluate its water content and look for signs of crystallization inside the bottle and around the lid. If there is even the slightest indication of crystallization, signs of evaporation, or the formation of solids in the bottle, **do not handle/touch/move the container** and contact **EH&S, 4-6200** immediately. Secure the area and restrict access to the container until it can be evaluated by EH&S personnel.

### **Explosives and Compounds with Shipping Restrictions**

A variety of other compounds that are classified as explosives or are water or air reactive are used in research laboratories. These compounds often have shipping restrictions and special packaging requirements. When disposing of these compounds, employees must ensure that they are stored appropriately for transport. Flammable metals must be completely submerged in oil prior to disposal. Many pyrophoric and reactive compounds can be stabilized using a quenching procedure prior to disposal. Chemicals classified by the Department of Transportation (DOT) as explosives (e.g., many nitro- and azo-compounds) will require special packaging and shipping, and may require stabilization prior to disposal. Consult with the Chemical Hygiene Officer and the Hazardous Waste Manager for disposal considerations of these compounds.

### **Particularly Hazardous Substances**

Waste containers containing particularly hazardous substances must be stored within a designated area. Waste containers with particularly hazardous substances should only be opened within a designated fume hood. Funnels used for particularly hazardous substance waste should be designated for that purpose.

## **MANAGING EMPTY CONTAINERS**

Empty containers do not have to be managed as hazardous waste. To be considered empty:

- No material can be poured or scraped from a container.
- An aerosol container must have its contents and pressure completely dispensed, and the spray mechanism in place and functional.

Notes and Exceptions:

- All containers that once held acutely / extremely hazardous materials are considered hazardous waste and must be disposed of by EH&S.
- If an empty hazardous material container is greater than five gallons, it must be picked up by EH&S.

## TRANSPORTATION

It is a violation of DOT regulations to transport hazardous waste in personal vehicles, or to carry hazardous waste across campus streets that are open to the public. As a result, EH&S provides pick-up services for all hazardous waste generators. These routine waste pick-ups are for routinely generated research wastes. Special pick-ups and laboratory clean-outs are available upon request.

For information on shipping hazardous materials please follow the link below:

<http://www.ehs.uci.edu/programs/dgoods/>

## DISPOSAL

Request a pickup via the internet:

- Visit [www.ehs.uci.edu/programs/enviro/](http://www.ehs.uci.edu/programs/enviro/)
- Fill out the “Chemical Waste Collection” form.
- EH&S will pick up your waste within 1-3 days.

Request a pickup via text message (detailed instructions can be found at <https://www.ehs.uci.edu/apps/waste/Text%20a%20Chemical%20Waste%20Request.pdf> or [https://www.ehs.uci.edu/apps/waste/text\\_to\\_collect.jsp](https://www.ehs.uci.edu/apps/waste/text_to_collect.jsp)):

- Text the message to [hwp@uci.edu](mailto:hwp@uci.edu)
- In the body of the text message include:
  - PI or Supervisor’s name
  - Location of the waste including the building and room number
  - KFS account number
  - And attached one or more pictures of the waste you would like to dispose of
- EH&S will pick up your waste within 1-3 days.

Do not dispose of chemicals by pouring them down the drain or placing them in the trash.

Do not use fume hoods to evaporate chemicals.

## Hazardous Waste Minimization

In order to reduce the amount of chemicals that become waste, administrative and operational waste minimization controls can be implemented. Usage of chemicals in the laboratory areas should be reviewed to identify practices which can be modified to reduce the amount of hazardous waste generated.

**Purchasing Control:** When ordering chemicals, be aware of any properties that may preclude long-term storage, and order only exact volumes to be used. Using suppliers who can provide quick delivery of small quantities can assist with reducing surplus chemical inventory. Consider establishing a centralized purchasing program to monitor chemical purchases and avoid duplicate orders.

**Inventory Control:** Rotate chemical stock to keep chemicals from becoming outdated. Locate surplus/unused chemicals and attempt to redistribute these to other users.

**Operational Controls:** Review your experimental protocol to ensure that chemical usage is minimized. Reduce total volumes used in experiments; employ small-scale procedures when possible. Instead of wet chemical techniques, use instrumental methods, as these generally require smaller quantities of chemicals. Evaluate the costs and benefits of off-site analytical services. Avoid mixing hazardous and non-hazardous waste streams. Use less hazardous or non-hazardous substitutes when feasible. Some examples include:

- Specialty detergents can be substituted for sulfuric acid/chromic acid cleaning solutions
- Gel Green and Gel Red are recommended in place of ethidium bromide

## **MERCURY THERMOMETER EXCHANGE PROGRAM**

Cleaning up spilled mercury from a broken thermometer is the most frequent EH&S HazMat response. Mercury is a potent neurotoxin and environmental contaminant, and UC has a goal of having a mercury free campus. EH&S will exchange mercury thermometers with non-mercury thermometers free of charge. To request an exchange of mercury thermometers, fill out the form at: <http://www.ehs.uci.edu/programs/enviro/MercuryFreeUCI.pdf>.



# Chapter 10: Accidents, Emergencies, and Chemical Spills

## Overview

Laboratory emergencies may result from a variety of factors, including serious injuries, fires, explosions, spills, exposures, and natural disasters. All laboratory employees should be familiar with and aware of the location of their laboratory's emergency response procedures and safety manuals. **Before beginning any laboratory task, know what to do in the event of an emergency situation.** Identify the location of safety equipment, including first aid kits, eye washes, safety showers, fire extinguishers, fire alarm pull stations, and spill kits. Plan ahead and know the location of the closest fire alarms, exits, and telephones in your laboratory. The UCI Emergency Procedures flip chart ([https://www.police.uci.edu/em/UCI\\_EmerProc.pdf](https://www.police.uci.edu/em/UCI_EmerProc.pdf)) provides an overview of emergency response procedures. The red emergency flip chart should be reviewed and understood prior to work with hazardous substances. It should be posted in an easily accessible location in every laboratory.

All incidents must be reported to the PI/Laboratory Supervisor and EH&S, 4-6200. Non-serious accidents, chronic exposures, and non-active spills do not constitute an emergency but should be reported to EH&S, 4-6200.

Near misses should be reported. Near misses can lead to incidents or injuries if the hazards are not reviewed, as outlined in Heinrich's Triangle Theory. Near misses should be reviewed with the goal of decreasing the probability of more serious incidences from taking place. Near misses or safety concerns can be reported online <https://www.ehs.uci.edu/apps/hr/index.jsp> or by calling EH&S, 4-6200.

### Heinrich's Triangle Theory



For all incidents requiring emergency response, call 911.

## Accidents

PIs/Laboratory Supervisors are responsible for ensuring that their employees receive appropriate medical attention in the event of an occupational injury or illness. Refer to the UC Irvine Injuries and Medical Treatment Poster located in every laboratory. All accidents and near misses must be reported to **the supervisor and EH&S, 4-6200**. An injury, incident or safety concern can also be reported to

EH&S online at <https://www.ehs.uci.edu/apps/hr/index.jsp>. EH&S will conduct an accident investigation and develop recommendations and corrective actions to prevent future accidents. At a minimum, each laboratory must have the following preparations in place:

- Fully stocked first aid kit
- Posting of emergency telephone numbers and locations of emergency treatment facilities
- Training of adequate number of staff in basic CPR and first aid
- Training of staff to accompany injured personnel to medical treatment site and to provide medical personnel with copies of SDS(s) for the chemical(s) involved in the incident

Accident Prevention Methods	
Do	Don't
<ul style="list-style-type: none"> <li>• Always wear appropriate eye protection</li> <li>• Always wear appropriate laboratory coat</li> <li>• Always wear appropriate gloves (i.e., ensure that the gloves are correct for the specific chemical used)</li> <li>• Always wear closed-toe shoes, and long pants</li> <li>• Always confine long hair and loose clothing</li> <li>• Always use the appropriate safety controls (e.g., certified fume hoods)</li> <li>• Always label, store, and dispose of chemicals properly</li> <li>• Always keep the work area clean and uncluttered</li> <li>• Always inspect glassware and equipment before use</li> <li>• Always promptly report any incidents, accidents, injuries, or near-misses to EH&amp;S</li> </ul>	<ul style="list-style-type: none"> <li>• Never enter the laboratory wearing inappropriate clothing (e.g., open-toe shoes and shorts) or without the proper PPE</li> <li>• Never work alone on procedures involving hazardous chemicals, biological agents, or other physical hazards</li> <li>• Never eat, drink, chew gum, chew tobacco, smoke, or apply cosmetics in the laboratory</li> <li>• Never use damaged glassware or other equipment</li> <li>• Never pour chemicals down the sink</li> <li>• Never mix incompatible chemicals</li> </ul>

If an employee has a severe or life threatening injury, call for emergency response at 911. Employees with minor injuries should be treated with first aid kits as appropriate, and sent to **Newport Urgent Care** at 1000 Bristol St N, #1b, [Newport Beach, CA 92660](https://www.newporturgentcare.com/), (949-752-6300) for evaluation and treatment. After normal business hours, treatment can be obtained at designated medical centers and emergency rooms.

**Serious occupational injuries, illnesses, and exposures to hazardous substances must be reported to the supervisor and EH&S, 4-6200 within 8 hours.** EH&S will report the event to Cal/OSHA, investigate the accident, and complete exposure monitoring if necessary. Serious injuries include those that result in permanent impairment or disfigurement, or require hospitalization. Examples include amputations, lacerations with severe bleeding, burns, concussions, fractures and crush injuries. As soon as PIs/Laboratory Supervisors are aware of a potentially serious incident, they must contact EH&S. EH&S must ensure that all serious injuries are reported to Cal/OHSA within 8 hours.

## Fire-Related Emergencies

If you encounter a fire, or a fire-related emergency (e.g., abnormal heating, smoke, burning odor), immediately follow these instructions:

1. Pull the fire alarm pull station **and call 911 from a campus phone or from an off-campus or cell phone** to notify the Fire Department;

2. Evacuate and isolate the area
  - Use portable fire extinguishers to facilitate evacuation and/or control a small fire (i.e., size of a small trash can), if safe to do so
  - If possible, shut off equipment before leaving
  - Close doors;
3. Remain safely outside the affected area to provide details to emergency responders; and
4. Evacuate the building when the alarm sounds. **It is against state law to remain in the building when the alarm is sounding.** If the alarm sounds due to a false alarm or drill, you will be allowed to re-enter the building as soon as the Fire Department determines that it is safe to do so. **Do not go back in the building until the alarm stops and you are cleared to reenter.**

**If your clothing catches on fire, go to the nearest emergency shower immediately. If a shower is not immediately available, then stop, drop, and roll (A fire extinguisher can be used if available).** Report to your supervisor and EH&S, 4-6200 within 8 hours every time a fire extinguisher is discharged. Anytime a fire extinguisher is used no matter how brief a period of time, inform EH&S as soon as possible. EH&S will ensure that your fire extinguisher is refilled and usable.

## Chemical Spills

Chemical spills can result in chemical exposures and contaminations. Chemical spills become emergencies when:

- The spill results in a release to the environment (e.g., sink or floor drain)
- The material or its hazards are unknown
- Laboratory staff cannot safely manage the hazard because the material is too hazardous or the quantity is too large (over 1 liter)

### Factors to Consider Before Spill Clean Up

1. Size of spill area
2. Quantity of chemical
3. Toxicity
4. Volatility
5. Cleanup materials available
6. Training of responders

Effective emergency response to these situations is imperative to mitigate or minimize adverse reactions when chemical incidents occur. After emergency procedures are completed, all personnel involved in the incident should follow UCI chemical exposure procedures as appropriate (see *Chapter 5: Chemical Exposure Assessment*).

In the event of a significant chemical exposure or contamination, immediately try to remove or isolate the chemical if safe to do so. When skin or eye exposures occur, remove contaminated clothing and flush the affected area using an eye wash or shower for at least 15 minutes. Obtain medical assistance as indicated on the SDS. If a chemical is ingested, follow the instructions on the SDS. Obtain medical assistance as indicated. Remember to wear appropriate PPE before helping others. PIs/ Laboratory Supervisors must review all exposure situations, make sure affected employees receive appropriate medical treatment and/or assessment, and arrange for containment and cleanup of the chemical as appropriate.

**Small chemical spills** can be cleaned up by laboratory personnel who have been trained in spill cleanup and with the appropriate materials. A small spill is generally defined as less than 1 liter of chemical that is not highly toxic, does not present a significant fire or environmental hazard, and is not in a public area such as a common hallway. **Large chemical spills** include spills of larger quantities, spills of any quantity of highly toxic chemicals, or chemicals in public areas or adjacent to drains. Large

spills require emergency response. Call **911 from a campus phone** or from an off-campus or cell phone for assistance.

## **WHAT TO DO WITH A SMALL CHEMICAL SPILL OF LOW HAZARD MATERIAL (NEVER CLEAN A SPILL THAT IS GREATER THAN 1 LITER, REGARDLESS OF THE MATERIAL) ONLY CLEAN A SPILL IF IT IS SAFE AND YOU FEEL COMFORTABLE**

- Evacuate all non-essential persons from the spill area
- If needed, call for medical assistance by dialing **911** from a campus phone or from an off-campus or cell phone
- Help anyone who may have been contaminated. Use emergency eyewashes/showers to flush the skin or eyes for **at least 15 minutes**. Remove any contaminated clothing. Make sure to have the appropriate PPE when helping others.
- Post someone just outside the spill area to keep people from entering. Avoid walking through contaminated areas
- You must have the proper protective equipment and clean-up materials to clean-up spills. Check the chemical's Safety Data Sheet (SDS) in your laboratory or online (<http://www.ucmsds.com>) for spill clean-up procedures, or call EH&S for advice, 4-6200
- Turn off sources of flames, electrical heaters, and other electrical apparatus, and close valves on gas cylinders if the chemical is flammable (stop ongoing processes if necessary)
- Remove any incompatible materials from the area
- Confine the spill to a small area. Do not let it spread
- Avoid breathing vapors from the spill. If the spill is in a non-ventilated area (confined space), do not attempt to clean it up. Call for emergency personnel to respond and clean up the spill
- Wear personal protective equipment, including safety goggles, gloves, and a laboratory coat or other protective garment to clean-up the spill (consult the SDS)
- Work with another person to clean-up the spill. Never clean-up a spill alone
- **DO NOT ADD WATER TO THE SPILL**
- Use an appropriate kit to neutralize and absorb inorganic acids and bases. For other chemicals, use the appropriate kit or absorb the spill with sorbent pads, paper towels, vermiculite, dry sand, or diatomaceous earth. For mercury spills and for all other spills requiring specialized clean-up procedures see Appendix I.



Collect the residue and place it in a clear plastic bag. Double bag the waste and label the bag with the contents. Fill out the "Chemical Waste Collection" form to request a pickup via the internet at <http://www.ehs.uci.edu/programs/enviro/>

## **WHAT TO DO WITH A LARGE CHEMICAL SPILL (>1 LITER)**

**Large chemical spills require emergency response. Call 911 from a campus phone or from an off-campus or cell phone. If the spill presents a situation that is immediately dangerous to life or health (IDLH) or presents a significant fire risk, activate a fire alarm, evacuate the area and wait for emergency response to arrive.**

- Call for emergency response/medical assistance by dialing **911**

- Remove the injured and/or contaminated person(s) and provide first aid
- Help anyone who may have been contaminated. Use emergency eyewashes/showers by flushing the skin or eyes for *at least 15 minutes*. Make sure to wear appropriate PPE when helping others.
- Evacuate laboratory. As you evacuate the laboratory, close the door behind you, and:
  - Post someone safely outside and away from the spill area to keep people from entering
  - Confine the spill area if possible and safe to do so
  - Leave on exhaust ventilation
  - If possible, turn off all sources of flames, electrical heaters, and other electrical equipment if the spilled material is flammable (stop ongoing processes if necessary)
  - Avoid walking through contaminated areas or breathing vapors of the spilled material
- Any employee with known contact with a particularly hazardous chemical must shower, including washing of the hair as soon as possible unless contraindicated by physical injuries

#### **Highly Toxic Chemical Spills**

***Do not try to clean up spills of any size of highly toxic chemicals. All spills require emergency response. Some examples of highly toxic chemicals include:***

- Aromatic amines
- Bromines
- Carbon disulfide
- Cyanides
- Ethers
- Hydrazine
- Nitriles
- Nitro-compounds
- Organic halides

# Appendices

## Appendix A: General Rules for Laboratory Work with Chemicals

### PRUDENT LABORATORY PRACTICES

It is prudent to minimize all chemical exposures. Few laboratory chemicals are without hazards. General precautions for handling all laboratory chemicals should be adopted, as well as specific guidelines for particular chemicals. Exposure should be minimized even for substances of no known significant hazard, and special precautions should be taken for work with substances that present special hazards. One should assume that any mixture will be more toxic than its most toxic component and that all substances of unknown toxicity are toxic.

Avoid inadvertent exposures to hazardous chemicals by developing and encouraging safe habits and thereby promoting a strong safety culture.

### SAFE LABORATORY HABITS

#### Personal Protective Equipment:

- Wear closed-toe and closed-heel shoes, full length pants, or equivalent as identified by the UC PPE policy, at all times when in the laboratory
- Utilize appropriate PPE while in the laboratory and while performing procedures that involve the use of hazardous chemicals or materials. These items may include but are not limited to laboratory coats, gloves, and safety glasses or goggles. Visit <https://www.ehs.uci.edu/programs/PPE/LabPPE.html>.
- Always completely button your laboratory coat and ensure there is no exposed areas between your gloves and laboratory coat
- Confine long hair and loose clothing and accessories
- Wear appropriate gloves when the potential for contact with toxic materials exists; inspect the gloves before each use, and replace them often. Make sure that the gloves are suitable for the material that is being worked with.
- Remove laboratory coats or gloves immediately upon contamination, as well as before leaving the laboratory. Wash your hands with soap and water upon leaving the laboratory.
- Avoid use of contact lenses in the laboratory unless necessary; if they are used, inform supervisor so special precautions can be taken
- Ensure that appropriate PPE is worn by all persons, including visitors, where chemicals are stored or handled
- Use appropriate respiratory equipment when air contaminant concentrations are not sufficiently restricted by engineering controls. Inspect the respirator before use. Use of respirators requires a respirator hazard assessment, successful completion of the EH&S Respirator Training, and Fit Test course. Visit UCI's Respiratory Protection Program at <http://www.ehs.uci.edu/programs/ih/respiratory.html>.



- Use any other protective and emergency apparel and equipment as appropriate. Be aware of the locations of first aid kits, emergency eyewash and shower stations, and other emergency or first aid equipment

### **Chemical Handling:**

- Use the smallest amount of chemical needed for the experiment.
- Use only those chemicals for which the quality of the available ventilation system is appropriate
- Vent apparatus which may discharge toxic chemicals (vacuum pumps, distillation columns, etc.) into local exhaust devices
- Properly label and store all chemicals, as outlined in Chapter 6. Use secondary containment at all times (secondary containment should be able to hold 100% volume of the largest container or 10% of the cumulative volume of all the containers, whichever is larger).
- Deposit chemical waste in appropriately labeled receptacles and follow all other waste disposal procedures of the Chemical Hygiene Plan. Segregate incompatible waste streams.
- Always read all labels and warning signs.
- In the case of an accident or spill, refer to the emergency response procedures for the specific material. These procedures should be readily available to all personnel. Information on minor chemical spill mitigation may also be referenced in Appendix I. For general guidance, the following situations should be addressed:
  - Eye Contact: Promptly flush eyes with water for a prolonged period (15 minutes minimum) and seek medical attention
  - Skin Contact: Promptly flush the affected area with soap and water for at least 15 minutes and remove any contaminated clothing, and seek medical attention
  - Clean-up: Promptly clean up spills, using appropriate protective apparel and equipment, and proper disposal.
    - If a spill is too large or the substance is particularly hazardous do not clean up the spill yourself. Anytime a spill occurs call EH&S, 4-6200, as soon as possible.

### **Equipment Storage and Handling:**

- Use equipment only for its designed purpose
- Store laboratory glassware with care to avoid damage. Use extra care with Dewar flasks and other evacuated glass apparatuses; always shield or wrap them to contain chemicals and fragments should implosion occur. This type of wrapping can include a plastic casing or a strong layer of electrical tape.
- Use certified fume hoods, glove boxes, or other ventilation devices for operations which might result in release of toxic chemical vapors or dust. Preventing the escape of these types of materials into the working atmosphere is one of the best ways to prevent exposure
  - Do not open, weight, or handle hazardous chemicals outside of the fume hood, volatile chemicals will release fumes which can be hazardous to inhale
- Keep hood closed at all times, except when adjustments within the hood are being made or when the hood is actively being used by a researcher
- Leave the fume hood "on" even when it is not in active use if toxic substances are in the fume hood or if it is uncertain whether adequate general laboratory ventilation will be maintained when it is "off"
- All electrical equipment should be grounded and kept in good condition

## Laboratory Operations:

- Keep the work area clean and uncluttered
  - Never have any equipment, chemicals, glassware, etc. in the work area if they are not currently being used
  - If possible, do not store waste in a work area that is being used
- Seek information and advice about hazards, plan appropriate protective procedures, and plan positioning of equipment before beginning any new operation
- If unattended operations are unavoidable, and have been approved by the PI/Laboratory Supervisor, place an appropriate sign on the door, leave lights on, and provide for containment of toxic substances in the event of failure of a utility service (such as cooling water)
- Be alert to unsafe conditions and ensure that they are corrected when detected
- If minors are in laboratories be sure to follow UC's Policy on Minors in Labs and Shops ([https://www.ucop.edu/risk-services/\\_files/safety-resources/minors-in-labs-and-shops.pdf](https://www.ucop.edu/risk-services/_files/safety-resources/minors-in-labs-and-shops.pdf) and <https://www.physiology.ucla.edu/images/Safety/uc-minors-in-labs-shops-policy-impacts.pdf>).
- Receive Lab Safety Fundamentals, any other relevant course in UCLC, read the chemical hygiene plan, read and sign the laboratory SOPs, and lab specific training prior to starting work in a lab
- Participate in both general training and lab specific training
- Cover all cuts, abrasions, open sores, and bruises with waterproof tape or a bandage and disposable gloves and report all injuries to your supervisor
- Keep all corridors doorways, and emergency exits clear and accessible
- Understand the procedures in case of an emergency (e.g., fire, earthquake, explosion, etc.)

## UNSAFE LABORATORY HABITS

### Personal Protective Equipment:

- Do not enter the laboratory without wearing appropriate clothing, including closed-toe and closed-heel shoes, and full length pants, or equivalent. The area of skin between the shoe and ankle should NEVER be exposed, wear pants that are long enough to cover this space.
- Do not wear laboratory coats or gloves outside of the laboratory area
- Never touch any non-work surface (door knob, your phone, computer, etc.) with gloves on
- Never wear or store your laboratory coat in a non-laboratory area, or a clean-area in the laboratory. Never sit at a desk in a clean-area with your laboratory coat on.
- Avoid use of contact lenses in the laboratory unless necessary. If they are used, inform supervisor so special precautions can be taken. If an irritation is observed remove the contact lenses immediately and rinse eyes with water, see medical attention if necessary.

### Chemical Handling:

- Do not smell or taste chemicals.
- Do not allow release of toxic substances or fumes into cold or warm rooms, as these types of areas typically involve re-circulated atmospheres.
- Never use mouth suction for pipetting or starting a siphon.
- Do not dispose of any hazardous chemicals through the sewer system. These substances might interfere with the biological activity of waste water treatment plants, create fire or explosion hazards, cause structural damage or obstruct flow



- Never store, even temporarily, bottles of chemicals near the sink

### **Equipment Storage and Handling:**

- Do not use damaged glassware or other equipment, under any circumstances. The use of damaged glassware increases the risks of implosion, explosion, spills, and other accidents
- Do not use uncertified fume hoods or glove boxes for hazardous chemical handling
- Do not store materials in hoods, and do not allow anything to block vents or air flow

### **Laboratory Operations:**

- Never work alone on procedures involving hazardous chemicals, biological agents, or other physical hazards
- Avoid unattended operations, if at all possible. Unattended operations require prior approval from the PI/Laboratory Supervisor
- Do not engage in distracting behavior such as playing a practical joke in the laboratory. This type of conduct may confuse, startle, or distract another worker

### **Food/Drink:**

- Do not eat, drink, smoke, chew gum, or apply cosmetics (including chapstick) in areas where laboratory chemicals are present; wash hands with soap and water before conducting these activities
- Do not store, handle, or consume food or beverages in storage areas, refrigerators, glassware or utensils which are also used for laboratory operations
- Wash areas of exposed skin well with soap and water before leaving the laboratory
- Do not put any objects (e.g., pencils, pens, fingers, swabs, etc) in the mouth, ears, or nose when working in a laboratory
- If possible, do not dispose of food/drink waste in laboratory trash containers



### **Mobile Devices:**

- Never touch your mobile device when wearing gloves.
- Never place your mobile device on any laboratory surface that may be contaminated with chemicals.
- Mobile devices can act as an ignition source. Do not use a mobile device when handling flammable materials. Never use a mobile device when using the solvent systems.

## Appendix B: Container Labeling

Chemical container labels are a good resource for information on chemical hazards. All containers of hazardous chemicals must have labels attached. Figure B.1 displays the label requirements.

Figure B.1. – Container Labeling Requirements



The warning may be a single word (e.g., Danger, Caution, Warning) and should identify the primary hazards, including both physical (e.g., water reactive, flammable, or explosive) and health (e.g., carcinogen, corrosive or irritant), such as what is found on an NFPA diamond and hazard warnings from the label or SDS.

Most labels provide additional safety information to help workers protect themselves from the substance. This information may include protective measures and/or protective clothing to be used, first aid instructions, storage information and emergency procedures.

### Chemical Labeling – What are Laboratory Personnel Responsible for?

- Inspecting incoming containers to be sure that labels are attached and are in good condition and contain the information outlined above
- Reading the container label each time a newly purchased chemical is used. It is possible that the manufacturer may have added new hazard information or reformulated the product since the last purchase
- Ensuring that chemical container labels are not removed or defaced, except when containers are empty
- Ensure that all containers containing a hazardous material are appropriately labeled, this includes a small aliquot that is transferred to a new bottle or vial
- Labeling any secondary containers used in the laboratory, to prevent unknown chemicals or inadvertent reaction
- Verifying that chemical waste containers have complete and accurate chemical waste labels

Labeling is important for the safe management of chemicals, preventing accidental misuse, inadvertent mixing of incompatible chemicals, and facilitating proper chemical storage. Proper labeling helps ensure quick response in the event of an accident, such as a chemical spill or chemical exposure

incident. Finally, proper labeling prevents the high costs associated with disposal of “unknown” chemicals.

With the exception of transient containers that will contain chemicals for immediate use, all containers of chemicals being used or generated in UC research laboratories must be labeled sufficiently to indicate the contents of the container. On original containers, the label MUST NOT be removed or defaced in any way until the container is emptied of its original contents. Incoming containers must be inspected to make sure the label is in good condition. It is also advisable to put a date on new chemicals when they are received in the laboratory, and to put a date on containers of chemicals generated in the laboratory. The initials of the responsible person should be on each container.

Abbreviations or other acronyms may be used to label containers of chemicals generated in the laboratory as long as a log sheet is posted in the laboratory that contains the code associated with content information. In addition, small containers, such as vials and test tubes, can be labeled as a group by labeling the outer container (e.g., rack or box). Alternatively, a placard can be used to label the storage location for small containers (e.g., shelf, refrigerator, etc.). This information must be provided to janitorial and maintenance staff as part of their hazard communication training.

Containers of practically non-toxic and relatively harmless chemicals MUST also be labeled with content information, including containers such as squirt bottles containing water.

With respect to chemical labeling, all chemicals transferred from their original container to a second container must be labeled with the chemical name and the principal hazards found on the primary container label or SDS.

For more information on labeling, see Chapter 6: Labeling, Storage, Inventory and Transport.

## Appendix C: SOP Instructions and Template

### Per OSHA, SOPs are Required when Working with Hazardous Chemicals

To determine if an SOP is needed, update your chemical inventory so that CiBR-Trac can identify the need for Banded SOPs and Chemical Specific SOPs.

Lab specific processes that involve hazardous materials and require SOPs should be identified by the PI and lab personnel.

### What is a Standard Operating Procedure (SOP)?

An SOP is a written document that clearly outlines the steps to be followed when carrying out a given operation or experiment so that a process can be replicated in a safe manner by any person reading it. It provides individuals with information to perform a procedure properly and facilitates consistency in the quality and integrity of the end result.

### Procedures and Requirements for Writing SOPs

**Step 1:** After identifying the needed SOPs, review the UCI EH&S SOP Template library ([http://www.ehs.uci.edu/programs/sop\\_library/](http://www.ehs.uci.edu/programs/sop_library/)) for templates of bands, processes, and chemicals or for a blank SOP template to use in order to complete your lab's SOPs. (Note: Labs are not required to use the EH&S SOP templates, but are required to complete SOPs).

**Step 2:** Using a template from the SOP library or by creating your own, customize it with lab-specific information and procedures/protocols. This has to be done by laboratory personnel with the most experience with the described procedure/protocol and/or chemical and who are routinely involved with the experimental process. **An SOP is not completed until lab specific procedures are included.**

**Step 3:** Once the SOP is written, it must be reviewed and signed by the PI and all personnel responsible for performing the procedures detailed by the SOP. Signing the SOP indicates that the signer understands the contents, requirements, and responsibilities.

**Step 4:** Maintain a copy of the signed SOP in the Laboratory Safety Binder or separately designated manual that is readily available to all lab personnel to review as required.

### SOP requirements at UCI

The UCI EH&S has created an SOP Template library ([http://www.ehs.uci.edu/programs/sop\\_library/](http://www.ehs.uci.edu/programs/sop_library/)) which will serve as a valuable tool for researchers in order to fulfill a Cal/OSHA requirement for the need of SOPs when working with hazardous chemicals. An SOP is not complete until the lab completes the procedure/protocol section of the document.

Three sub-categories were created in order to help researchers avoid unnecessary work and to make these documents useful in research.

The first category is called "**Banded SOPs**". All chemicals with the help of CiBR-Trac (UCI Chemical Inventory Program) are placed under specific bands. In order to classify these chemicals the chemical inventory program takes in account specific physical and chemical properties as well as physical and/or health hazards. Several chemicals will fall under more than one bands but the primary band that will be identified by the program will be the important one for each chemical. The primary chemicals from each band that are not in use can be marked as "**Not in use**" or "**For storage only**". A process or procedure/protocol has to be described when chemicals are in use. Clear instructions on banded and chemical specific SOP can be found in Chemical Inventory program (CiBR-Trac) at the SOP tab when the PI or lab manager signs in. Other bands could also be created by individual labs with families of chemicals that are used in a reaction the same way like Grignard reagents, organo-lithium reagents, etc.

The second category is called "**Process SOPs**". PIs and lab personnel have to identify specific hazardous processes performed regularly at their locations and SOPs have to be created for them.

The template library has several process SOPs in place but labs will have to customize accordingly. A process could include the use of specific equipment like rotary evaporators, centrifuges, and etc. A process could also include specific known reactions that are regularly performed by lab personnel like Heck reaction, Suzuki reaction, etc.

The third category is the “**Chemical Specific SOPs**”. All regulated carcinogens are required by Cal/OSHA to have individual SOPs. Chemicals utilized for animal research and are included in animal protocols are also required to have SOPs. Templates for these chemicals can be found at the EH&S SOP template library as well as the electronic chemical inventory program. The lab can chose to also maintain individual chemical SOPs for all primary chemicals in the bands.

### **Steps to follow for identifying lab SOPs needed for lab operations**

**Step 1:** Update the lab Chemical Inventory by adding new chemicals when they arrive and removing chemicals that have been completely used and container has been disposed of. On an annual basis researchers should verify the validity of their inventory and make all necessary additions and removals.

**Step 2:** CiBR-Trac will help identify the bands and the chemicals that fall under every band.

**Step 3:** CiBR-Trac will help identify what chemicals require individual SOPs. In addition to regulated carcinogens, any chemical included in an animal protocol is required to have an SOP.

**Step 4:** CiBR-Trac will help identify all Exhibit 1 chemicals and the band they belong to. These chemicals are required to have the procedure/protocol section completed. This applies only to the Settlement labs.

**Step 5:** PI and/or lab personnel need to identify lab specific processes. These could be specific, known or regularly used reactions or procedures. These could also be certain commonly used equipment.

### **Proposed Bands**

Primary Bands: Chemicals that fall under these bands pose an immediate hazard to the worker or are regulated and require chemical specific procedures within the SOP.

1. Regulated Carcinogens
2. Strong corrosive chemicals
3. Water Reactive chemicals
4. Air reactive chemicals
5. Acutely toxic chemicals (LD50 equals or lower than 50mg/kg for rats)
6. Explosive chemicals
7. Highly Flammable chemicals
8. Peroxide forming chemicals
9. Toxic gases

All regulated carcinogens are required by Cal/OSHA to have an individual SOP for each chemical.

Secondary Bands: Chemicals that fall under these bands can have a generic procedure that covers all chemicals under each band. These bands will have two sub categories: Solvents, non-solvents.

1. Carcinogens and reproductive toxicants
2. Flammable chemicals
3. Corrosive chemicals
4. Potentially explosive chemicals and Oxidizers
5. Sensitizers, Irritants and toxic chemicals
6. Compressed Gases
7. Harmful and lower hazard chemicals
8. Non hazardous chemicals

## How to Write an SOP Protocol or Procedure

### SOP Protocol or Procedure

Templates from the UCI EH&S SOP Template library ([http://www.ehs.uci.edu/programs/sop\\_library/](http://www.ehs.uci.edu/programs/sop_library/)) must be customized, by lab groups using chemicals, to include lab-specific information. In particular, the labs must complete the protocol/procedure section of the SOP detailing the use of chemicals or equipment so that it can be followed safely and consistently. It is important that this section is written by the most experienced and knowledgeable lab personnel for the various uses of the chemicals or equipment and reviewed by the PI. SOPs are required in order to work with hazardous chemicals listed as per Cal-OSHA.

### Steps for Writing Protocols/Procedures

**Step 1:** Give a general range of quantities that can be used in a safe and consistent manner. If necessary provide two procedures to cover a wider range of quantities.

**Step 2:** Outline the conditions under which the procedure applies (temperature, pressure).

**Step 3:** Provide a step-by-step explanation of a general experimental procedure covered within the range of quantities. Provide details on the engineering controls and hazards associated with the procedure.

**Step 4:** Include a specific example procedure describing in detail the experiment. This could be an experimental procedure from your lab notebook or from a publication.

**Step 5:** If quantities or conditions significantly deviate from the SOP be sure to obtain approval from the PI, and include any changes to an updated SOP.

### Example:

#### Protocol / Procedure

**Quantities covered by this SOP:** 0 – 40 g

**Conditions covered by this SOP:** 0 °C – 50 °C

**General:** Sodium hydroxide pellets are used to make aqueous solutions that range from 0.01 M to 1 M and volume of 10 ml to 1 L. The sodium hydroxide pellets are weighed and then slowly added to a beaker of water that is cooled in an ice bath under constant stirring on a stirring plate. Caution: Dissolution of sodium hydroxide is highly exothermic. The solution is stirred until all sodium hydroxide is dissolved. It is then allowed to reach room temperature. The final concentration is determined by titration with potassium hydrogen phthalate.

**Example:** Preparation of 1L of 1M sodium hydroxide solution.

40 g of NaOH pellets was weighed out in a plastic weigh boat. A 2 L beaker containing 1 L of water and a stirring magnet was placed in an ice bath over a stirring plate. The pellets were added slowly to the water. When all pellets were completely dissolved the beaker was removed from the ice bath and allowed to reach room temperature before solution got titrated with potassium hydrogen phthalate.

**NOTE:** Any deviation from this SOP requires approval from PI.

# Appendix D: Safe Use of Particularly Hazardous Substances

## Safe Handling of Particularly Hazardous Substances Guidelines

### I. REFERENCES

1. Title 8, California Code of Regulations (CCR), Section 5191 (Occupational Exposures to Hazardous Chemicals in Laboratories; Article 110 (Regulated Carcinogens); Section 5209 (Listed Carcinogens); Section 5203 (Report of Use Requirements); Section 5154.1 (Ventilation Requirements for Laboratory-Type Hood Operations);

### II. PURPOSE

To provide general guidance on how to work safely with chemicals that have been designated as “particularly hazardous” by Cal/OSHA. It describes the minimum requirements for the safe storage, use, handling, and disposal of particularly hazardous substances, including spill and accident response procedures. Particularly hazardous substances are defined by Cal/OSHA as: reproductive toxins, acutely toxic substances and select carcinogens, which include regulated carcinogens.

### III. STATEMENT

These guidelines apply to all UCI laboratory workers (e.g., Principal Investigators, laboratory personnel, students, visiting researchers, etc.) who use or work with particularly hazardous substances. Careful handling and stringent controls of these chemicals are essential to protect workers and the environment, and to comply with Cal/OSHA regulations.

Additional safety requirements may apply, depending on the specific chemical. For example, carcinogens that are also highly flammable require both particularly hazardous substance controls as well as fire safety controls. Contact EH&S, 4-6200 for guidance on use of chemicals that may require further controls.

### IV. LABORATORY SAFETY REQUIREMENTS & PROCEDURES

#### A. Laboratory Specific Standard Operating Procedures

1. Individual laboratory groups must prepare and maintain laboratory-specific standard operating procedures (SOP) for identifying hazards and handling methods to avoid exposure to particularly hazardous substances. The procedures must indicate the designated use areas, limitations on the quantities and procedures used, information on containments, and information on the hazards involved. These procedures may be specific to particular substances or generalized over a group of chemicals with similar hazardous properties and use limitations. Chemical-specific procedures must be developed for each Cal/OSHA regulated carcinogen and procedures should be developed for reproductive toxins, acutely toxic materials, and select carcinogens.
2. A copy of the particularly hazardous substances procedures, including laboratory specific information, and the Safety Data Sheets (SDS) for the chemical(s) used must be readily accessible in the lab.

3. EH&S MUST be notified immediately if members of the laboratory become ill or exhibit signs or symptoms associated with exposure to hazardous chemicals used in the laboratory. Affected employees must be provided immediate first aid and medical surveillance within 24-hours of the event.
4. Principal Investigators must identify what classes of particularly hazardous substances are in use in their labs and identify the appropriate personal protective equipment (PPE) on their Laboratory Hazard Assessment Tool, which must be completed as conditions change in the laboratory, or at least once each calendar year.

## **B. Training and Documentation**

1. All laboratory personnel who work with or may be exposed to particularly hazardous substances must be provided laboratory-specific training and information by the Principal Investigator or their designee prior to beginning their initial assignment. Laboratory-specific training should cover specific policies and procedures, etc. and is in addition to the basics covered in the Laboratory Safety training. Records of laboratory-specific training must be maintained in the laboratory and should include an outline of the topics covered. See [http://www.ehs.uci.edu/programs/iipp/Work\\_Unit-Specific\\_Training\\_Roster.doc](http://www.ehs.uci.edu/programs/iipp/Work_Unit-Specific_Training_Roster.doc) for a sample documentation form. Training shall include:
  - The hazards/toxicological effects associated with the chemicals being used.
  - Routine procedures and decontamination methods.
  - Emergency response practices and procedures.
  - Methods and observations for detecting the presence or release of hazardous chemicals.
  - Available protection measures, including appropriate work practices and personal protective equipment (PPE).
  - A review of written SOPs, SDSs, and the Chemical Hygiene Plan (CHP).
  - A review of these guidelines.
2. All laboratory personnel are responsible for knowing and complying with all safety guidelines, regulations, and procedures required for the task assigned. They are also responsible for reporting unsafe conditions, accidents or near misses to the Principal Investigator, immediate laboratory management staff or EH&S.
3. Continuing training shall be conducted as needed to maintain a working knowledge of hazards and the safety requirements for all laboratory personnel who work with particularly hazardous substances. Written records must be maintained for each training session. See [http://www.ehs.uci.edu/programs/iipp/Work\\_Unit-Specific\\_Training\\_Roster.doc](http://www.ehs.uci.edu/programs/iipp/Work_Unit-Specific_Training_Roster.doc) for a sample documentation form.

## **C. Use in Designated Areas**

1. Designated area(s) for use of particularly hazardous substances must be formally established by developing SOPs and posting appropriate signage. This designated area(s) may be an entire laboratory, a specific work bench, or a chemical fume hood. When particularly hazardous substances are in use, access to the designated area shall be limited to personnel following appropriate procedures and who are trained in working with these chemicals.
2. Access to areas where particularly hazardous substances are used or stored must be controlled by trained employees. Working quantities of particularly hazardous substances should be kept as small as practical and their use should be physically contained as much as possible, usually within a laboratory fume hood or glove box. It is the responsibility of each



Principal Investigator, or their designee, to train and authorize their staff for these operations and to maintain documentation of this training and authorization.

3. Signage is required for all containers, designated work areas and storage locations. Sign wording must state the following, or similar, as appropriate for the specific chemical hazard:

“DANGER, CANCER HAZARD – SUSPECT AGENT”

“DANGER, CANCER HAZARD – REGULATED CARCINOGEN”

“DANGER, REPRODUCTIVE TOXIN”

“DANGER, ACUTE TOXIN”

Entrances to designated work areas and storage locations must include signage, “AUTHORIZED PERSONNEL ONLY”, in addition to the above specific hazard warning wording. Signage templates can be obtained from the UC Chemistry and Biochemistry safety webpage.

4. Work surfaces should be stainless steel, plastic trays, dry absorbent plastic backed paper, chemically resistant epoxy surfaces, or other chemically impervious material.
5. Protocols, procedures, and experiments must be designed and performed in a manner to safely maintain control of the particularly hazardous substances. Laboratory personnel must specifically consult with their Principal Investigators if a special hazard is involved (e.g., material under pressure) or if they are uncertain of the potential hazards.

#### **D. Personal Protective Equipment (PPE)**

1. PPE must be sufficient to protect eyes, skin, and lungs from contact with the hazardous agents. At minimum, safety glasses, lab coat, long pants, closed-toed shoes, and gloves are required when working with particularly hazardous substances. For more information visit <https://www.ehs.uci.edu/programs/PPE/LabPPE.html>. Goggles are required for processes in which a splash or spray hazard exist and flame-resistant lab coats maybe required if the chemicals being used are flammable. Respirators might also be required if engineering controls are not adequate or not available.
2. Refer to the specific chemical’s SDS and SOP for specific information on additional PPE and glove selection.
3. Contaminated PPE and clothing must be disposed of or decontaminated prior to removal from the designated work area. While small spots of contamination may be cleaned in the lab, grossly contaminated lab coats may need to be disposed of as dry hazardous waste. Refer to <https://www.ehs.uci.edu/programs/PPE/LabPPE.html> and the Chemical Hygiene Plan for guidance on handling contaminated protective apparel and other PPE.

#### **E. Engineering Controls**

1. Bench top work with particularly hazardous substances should be avoided whenever practical in favor of contained systems (such as fume hoods or glove boxes) and is not permitted if there is a reasonable likelihood of workers exceeding regulatory exposure limits. For questions regarding exposure limits and for assistance in conducting a hazard assessment for uncontained procedures, contact EH&S, 4-6200.
2. Laboratories and rooms where particularly hazardous substances are used outside of containment systems must have general room ventilation that is maintained at negative

pressure with respect to public areas. Air from these ventilation systems must be vented externally; recirculation is not permitted. Doors providing access from public areas must be kept closed. It is not permitted if there is a reasonable likelihood of workers exceeding regulatory exposure limits. For questions regarding exposure limits and for assistance in conducting a hazard assessment for uncontained procedures, contact EH&S, 4-6200.

#### **F. Special Handling & Storage Requirements**

1. Particularly hazardous substances must be stored in a designated area and used in a manner that will minimize the risk of accidental release (e.g., capped tightly, use of chemical resistant secondary containment, whenever possible). Laboratory personnel should remove chemicals from storage only as needed and return them to storage as soon as practical.
2. Chemicals should be segregated from incompatible materials, as described in the UC Chemical Hygiene Plan. The use of particularly hazardous substances must be confined to an established designated area (see Section C. Use in Designated Areas, above).
3. Additional requirements for the safe storage of a specific chemical may be found in the manufacturer's instructions or in the SDS.
4. When transporting chemicals beyond the immediate laboratory environment, containers should be protected from breakage by using a bottle carrier or other effective secondary containment.
5. Contact EH&S, 4-6200 for guidance on the planned use of chemicals that may require further controls.

#### **G. Spill & Accident Procedures**

1. Immediate measures must be available to prevent the possible spread of contamination in the event of a small spill of a particularly hazardous substance. Absorbent materials and cleanup materials should be available in all laboratories sufficient to contain and decontaminate individuals, equipment, and areas. Any known spills must be contained and decontaminated as soon as possible. Any drains near the spill need to be protected.
2. In the event of a large spill that is beyond a laboratory group's immediate response capabilities, the following procedures should be followed:
  - a. Evacuate the area immediately.
  - b. Restrict access to the affected areas to emergency responders and post signage and barriers as needed to prevent unauthorized entry.
  - c. Contact EH&S immediately for response. Call 911 from a UC campus phone or from a cell phone (to UCIPD).
3. In the event of direct eye or skin contact with a particularly hazardous substance, the affected person must shower or flush the affected areas for a minimum of 15 minutes. Whenever personal contamination occurs, the event must be reported to EH&S at 4-6200 and an incident report will be completed and maintained by EH&S.
4. If the spill involves acutely toxic materials, the spill should be treated as a large spill if there is any doubt about the group's ability to safely mitigate the spill.
5. If the spill involves regulated carcinogens, a Report of Use may need to be filed (see J. Regulated Carcinogens and Report of Use Requirements, below).

## **H. Routine Decontamination Procedures**

1. To limit the spread of contamination, laboratory work surfaces should be decontaminated at the conclusion of each procedure and at the end of each day on which particularly hazardous substances are used.
2. All equipment should be decontaminated before removing it from the designated area; this decontamination should be carried out in a glove box or fume hood where practical.
3. Contaminated PPE must not be removed from the designated area until properly decontaminated. After working with these chemicals, gloves must immediately be removed and disposed of as hazardous waste and hands and arms washed with soap and water.

## **I. Waste Disposal Procedures**

1. Disposal of waste materials that include particularly hazardous substances must comply with the hazardous chemical waste disposal procedures found in the Chemical Hygiene Plan.
2. In addition to general hazardous waste labeling requirements, waste containers containing particularly hazardous substances must also be labeled as appropriate for the specific chemical hazard:
  - “DANGER, CANCER HAZARD – SUSPECT AGENT”
  - “DANGER, CANCER HAZARD – REGULATED CARCINOGEN”
  - “DANGER, REPRODUCTIVE TOXIN”
  - “DANGER, ACUTE TOXIN”
3. All non-radioactive chemical waste must be disposed of through the UCI Hazardous Waste Management Program. Due to regulatory restrictions and the high cost of disposal, the Radiation Safety Department should be contacted prior to producing mixed wastes of hazardous chemicals and radioactive material.

## **J. Regulated Carcinogens and Report of Use Requirements**

1. Regulated carcinogens are a specific subset of select carcinogens which have special additional requirements associated with their use under certain circumstances. See Attachment B for the specific list. EH&S maintains an air sampling program to monitor individuals to determine if they are, or may reasonably be expected to, exceed short or long term exposure limits. Every effort should be made to minimize exposure and keep exposure levels below these limits by using fume hoods, limiting the quantities used, and following SOPs designed to reduce exposure. If levels of regulated carcinogens cannot be kept below these levels, additional requirements may include:
  - Required medical evaluations.
  - Additional documented training.
  - Use of respirators with required initial and ongoing training, medical evaluations, and maintenance documentation.
  - Additional documented hazard evaluations.
2. Listed carcinogens are a further subset of regulated carcinogens. See Attachment C for the specific list. The use of these materials must be registered with EH&S through an EH&S approved process. If you have or intend to purchase any of these chemicals first consult with

EH&S at 4-6200. An evaluation will be completed to assess safety requirements for groups that use these materials.

Report of Use Requirements must be met for each group when they:

- Begin the use of, or make significant changes to existing use of any listed carcinogen.
- Use regulated carcinogens such that there is a reasonable expectation that exposure limits may be exceeded.
- In the event of an emergency in which employees have been exposed to any regulated carcinogen.

## **V. ATTACHMENTS**

- A. Particularly Hazardous Substances Definitions
- B. Regulated Carcinogens
- C. Listed Carcinogens

## ATTACHMENT A

### Particularly Hazardous Substances Definitions

Particularly hazardous substances fall into the following three major categories: acutely toxicants, reproductive toxins, and carcinogens.

#### Section 1.01 Acutely Toxicants

Substances that have a high degree of acute toxicity are substances that may be fatal or cause damage to target organs as the result of a single exposure or exposures of short duration. They can be defined as:

1. A chemical with a median lethal dose (LD50) of 50 mg or less per Kg of body weight when administered orally to albino rats weighing between 200 and 300 g each;
2. A chemical with a median lethal dose (LD50) of 200 mg or less per Kg of body weight when administered by continuous contact for 24 hours (or less if death occurs within 24 hours) with the bare skin of albino rabbits weighing between 2 and 3 Kg each; and
3. A chemical that has a median lethal concentration (LC50) in air of 5000 ppm by volume or less of gas or vapor, or 50 mg per liter or less of mist, fume, or dust, when administered by continuous inhalation for 1 hour (or less if death occurs within 1 hour) to albino rats weighing between 200 and 300 g each.

#### Section 1.02 Reproductive Toxins

Reproductive toxins include any chemical that may affect the reproductive capabilities including chromosomal damage (mutations) and effects on fetuses (teratogenesis). A list of reproductive toxins is maintained online at [http://www.oehha.ca.gov/prop65/prop65\\_list/Newlist.html](http://www.oehha.ca.gov/prop65/prop65_list/Newlist.html) or <https://oehha.ca.gov/media/downloads/proposition-65//p65list062819.pdf>.

#### Section 1.03 Carcinogens

Carcinogens are chemical or physical agents that cause cancer. Generally, they are chronically toxic substances; that is, they cause damage after repeated or long-duration exposure, and their effects may only become evident after a long latency period.

The term “regulated carcinogen” means a recognized cancer causing substance, compound, mixture, or product regulated by Cal/OSHA sections 1529, 1532, 1532.2, 1535, 8358, 8359 or Article 110, sections 5200-5220. *See Attachment B for the specific list of Regulated Carcinogens.*

The term “Listed Carcinogen” refers to a specific list of 13 chemicals regulated by Cal/OSHA and Federal OSHA and has specific use and handling requirements. *See Attachment C for the specific list of Listed Carcinogens.*

The term “select carcinogen” refers to a category of chemicals where the available evidence strongly indicates that the substances cause human carcinogenicity. A select carcinogen meets one of the following criteria:

1. It is regulated by Cal/OSHA as a carcinogen; or
2. It is listed under the category “known to be carcinogens” in the annual report by the National Toxicology Program (NTP); or

3. It is listed under Group 1 – “carcinogenic to humans” – by the International Agency for Research on Cancer (IARC); or
4. It is listed in either Group 2A or Group 2B by the IARC or under the category “reasonably anticipated to be carcinogens” by the NTP, and causes statistically significant tumor incidence in experimental animals in accordance with any of the following criteria:
  - a. After inhalation exposure of 6-7 hours per day, 5 days per week, for a significant portion of a lifetime to dosages of less than 10 mg/m<sup>3</sup>;
  - b. After repeated skin application of less than 300 mg/kg of body weight per week; or
  - c. After oral dosages of less than 50 mg/kg of body weight per day.

## ATTACHMENT B

### Regulated Carcinogens



The term “regulated carcinogen” means a recognized cancer causing substance, compound, mixture, or product regulated by Cal/OSHA sections 1529, 1532, 1532.2, 1535, 8358, 8359 or Article 110, sections 5200-5220.

- Acrylonitrile
- Arsenic metal and inorganic arsenic compounds
- Asbestos
- Benzene
- Beryllium
- 1,3-butadiene
- Cadmium metal and cadmium compounds
- Chromium(VI) compounds
- Coke Oven Emissions
- 1,2-Dibromo-3-chloropropane (DBCP)
- Ethylene Dibromide (EDB)
- Ethylene Oxide (EtO)
- Formaldehyde gas and formaldehyde solutions
- Lead metal and inorganic lead compounds
- Methylene Chloride
- 4,4'-Methylene bis(2-chloroaniline) (MBOCA)
- Methylenedianiline (MDA)
- Vinyl Chloride
- 2-Acetylaminofluorene
- 4-Aminodiphenyl
- Benzidine (and its salts)
- 3,3'-Dichlorobenzidine (and its salts)
- 4-Dimethylaminoazobenzene
- alpha-Naphthylamine
- beta-Naphthylamine
- 4-Nitrobiphenyl
- N-Nitrosodimethylamine
- beta-Propiolactone
- bis-Chloromethyl ether
- Methyl chloromethyl ether
- Ethyleneimine

## ATTACHMENT C

### Listed Carcinogens



The term “listed carcinogen” refers to a specific list of 13 chemicals regulated by Cal/OSHA and Federal OSHA and has specific use and handling requirements.

- 2-Acetylaminofluorene
- 4-Aminodiphenyl
- Benzidine (and its salts)
- 3,3'-Dichlorobenzidine (and its salts)
- 4-Dimethylaminoazobenzene
- alpha-Naphthylamine
- beta-Naphthylamine
- 4-Nitrobiphenyl
- N-Nitrosodimethylamine
- beta-Propiolactone
- bis-Chloromethyl ether
- Methyl chloromethyl ether
- Ethyleneimine



# Appendix E: Respiratory Hazard Assessment Form

(Part 1: To be completed by Employee)

## UCI EH&S Respiratory Hazard Evaluation Part 1

Job Title:		Date:	
Department:			
Supervisor Name:		Phone Extension:	Email:
<b>Employees Represented by Evaluation:</b>			
<i>Name</i>	<i>UCI Net ID</i>	<i>Name</i>	<i>UCI Net ID</i>
<b>Process Description:</b>			
<b>Identity of Contaminant(s)/Hazard(s)?</b>	<b>Quantity of contaminant per unit time:</b>	<b>of used</b>	<b>Duration of Exposure:</b>
<b>Controls and/or personal protective equipment being used to minimize or eliminate exposure?</b>			
<b>Expected work effort:</b> <b>physical</b> <input type="checkbox"/> High <input type="checkbox"/> Moderate <input type="checkbox"/> Low			

*Physical Work Effort Key (based on ACGIH TLV and BEI handbook)*

**High:** *Examples of activities are sawing by hand, shoveling dry/wet sand, intermittent heavy lifting with pushing or pulling*

**Moderate:** *Examples of activities are scrubbing in standing position, walking about with moderate lifting or pushing*

**Low:** *Examples of activities are sitting with moderate arm and leg movements, standing with light work at machine or bench while using mostly arms or with some walking about*

Obtain this form online at: <http://www.ehs.uci.edu/programs/ih/respiratory.html>

**(Part 2: To be completed by EH&S)**

**UCI EH&S Respiratory Hazard Evaluation Part 2**

Evaluation By:		Reviewed By:		<input type="checkbox"/> New	<input type="checkbox"/> Revised
What type of respiratory hazard is present?		<input type="checkbox"/> Oxygen Deficiency	<input type="checkbox"/> Gas/Vapor	<input type="checkbox"/> Particulate/Aerosol	Rev. Date
		<input type="checkbox"/> Combination	<input type="checkbox"/> Biohazard		
Respiratory Hazard(s)	TLV? <sup>1</sup>	STEL/PEL? <sup>1</sup>	Concentration in the atmosphere? <sup>2</sup>		
1 Mark "NONE" if value is not available					
2 Provide reasonable estimate if sampling data is not available					
Relative Humidity: (report potential range)			Temperature: (report potential range)		
Are IDLH conditions possible?		<input type="checkbox"/> No <input type="checkbox"/> Yes	Is hazard an eye irritant?		<input type="checkbox"/> No <input type="checkbox"/> Yes
Are engineering controls available?		<input type="checkbox"/> No <input type="checkbox"/> Yes	Is hazard absorbed through the skin?		<input type="checkbox"/> No <input type="checkbox"/> Yes
Is a respirator required?		<input type="checkbox"/> No <input type="checkbox"/> Yes (Based on exposure/potential/protocol) <input type="checkbox"/> Voluntary Use only Article II. provide Appendix D (Respiratory Protection Program)	Check all that apply: <input type="checkbox"/> Half face <input type="checkbox"/> SCBA <input type="checkbox"/> PAPR		(Refer to Appendix B (Respiratory Protection Program)- Respirator Decision Logic Sequence) <input type="checkbox"/> Full Face <input type="checkbox"/> Air line <input type="checkbox"/> Filtering Facepiece
Cartridge type(s) to be issued and approximate weight of respirator + cartridge(s): (Refer to Appendix B (Respiratory Protection Program)- Respirator Decision Logic Sequence)					
Recommended Change Schedule for Cartridges: (NOTE: For formaldehyde, change cartridges every 3 hours)					
Additional required and/or recommended P.P.E. (personal protective equipment)					
Expected duration and frequency of respirator use:					

## UCI EH&S Respiratory Protection Voluntary Use Affidavit

Date \_\_\_\_\_

Department \_\_\_\_\_

Location \_\_\_\_\_

Process/Procedure:

--

Respirator Information (Brand, Type, etc): \_\_\_\_\_

I/We understand that a respiratory hazard evaluation was performed to determine the need for respiratory protection while performing the abovementioned process/procedure.

I/We acknowledge that the results of the evaluation indicate that respirator use is not required while performing the abovementioned process/procedure and that any respirator use during the process/procedure is strictly **voluntary**.

In addition, I/we further acknowledge that I/we received training on the proper use and limitation of the respirator and received a copy of Appendix D "Information for Employees Using Respirators When Not Required Under the Standard" pursuant to all applicable Respiratory Protection standards.

Print Name	Signature

# Appendix F: Peroxide Forming Chemicals Common to Research

## Class 1 PFCs

Class 1 chemicals form explosive levels of peroxides without concentration; these are the most hazardous and can form explosive peroxide levels even if not opened. The chemicals listed below should be tested for the formation of peroxides on a periodic basis. Several methods are available to check for peroxides; the two most common are the use of peroxide test strips or the potassium iodide test. These chemicals should be **tested for peroxide formation or discarded after 3 months of receiving the chemicals**.



Class 1 PFC examples		
Isopropyl ether	Potassium amide	Vinylidene chloride
Divinyl acetylene	Potassium metal	
Divinyl ether	Sodium amide	

## Class 2 PFCs

This group of chemicals will readily form peroxides when they become concentrated (e.g., via evaporation or distillation). The concentration process defeats the action of most auto-oxidation inhibitors. As a result, these chemicals should be tested for peroxide formation or disposed of within 12 months of receiving.

Class 2 PFC examples		
Acetal	Diethylether	Methyl isobutyl ketone
Cumene	Dioxane	Tetrahydrofuran
Cyclohexene	Ethylene glycol dimethyl ether	Tetrahydronaphthalene
Cyclopentene	Furan	Vinyl ethers
Diacetylene	Methylacetylene	
Dicyclopentadiene	Methylcyclopentane	

## Class 3 PFCs

This group of chemicals forms peroxides due to initiation of polymerization. When stored in a liquid state, the peroxide forming potential dramatically increases. These chemicals should be **tested for peroxide formation or discarded after 12 months**.

Class 3 PFC examples		
Acrylic acid	Chlorotrifluoroethylene	Vinyl acetate
Acrylonitrile	Methyl methacrylate	Vinyl acetylene Vinyl chloride
Butadiene	Styrene	Vinyl pyridine
Chlorobutadiene	Tetrafluoroethylene	Vinylidene chloride

# Appendix G: Safe Use of Pyrophoric Reagents

## Procedures for Safe Use of Pyrophoric Reagents

### I. Introduction

In December 2008, a laboratory accident at UCLA occurred while the researcher was working with tert-butyl lithium, a highly pyrophoric agent. Pyrophoric materials ignite spontaneously on contact with air; these chemicals react with oxygen, moisture in the air, or both. Failure to follow proper handling procedures can result in fire or explosion, leading to serious injuries/death or significant damage to facilities. Good technical guidance can be found in **Aldrich Technical Bulletins AL-134 and AL-164** (<https://www.sigmaaldrich.com/chemistry/chemical-synthesis/learning-center/technical-bulletins.html>)

Below are some procedures describing the hazards, proper handling, disposal and emergency procedures when working with pyrophoric materials.

### II. Examples of Pyrophoric Materials

Grignard Reagents:  $\text{RMgX}$  (R=alkyl, X=halogen)

Metal alkyls and aryls: Alkyl lithium compounds; tert-butyl lithium

Metal carbonyls: Lithium carbonyl, nickel tetracarbonyl

Metal powders (finely divided): Cobalt, iron, zinc, zirconium

Metal hydrides: Sodium hydride

Nonmetal hydrides: Diethylarsine, diethylphosphine

Non-metal alkyls:  $\text{R}_3\text{B}$ ,  $\text{R}_3\text{P}$ ,  $\text{R}_3\text{As}$ ; tetramethyl silane, tributyl phosphine

Phosphorus

Potassium

Sodium

Gases: Silane, dichlorosilane, diborane, phosphine, arsine

A more extensive list of pyrophoric compounds can be found in Bretherick's *Handbook of Reactive Chemical Hazards*.

### III. Hazards

Pyrophorics must be handled under inert atmospheres and in such a way that rigorously excludes air/moisture since they ignite on contact with air and/or water. They all tend to be toxic and many come dissolved in a flammable solvent. Other common hazards include corrosivity, teratogenicity, water reactivity, peroxide formation, along with damage to the liver, kidneys, and central nervous system. Be especially vigilant when working with tert-butyl lithium which is **extremely pyrophoric**. Researchers working with pyrophoric materials must be proficient and must not work alone!

### IV. Controlling the Hazards

BEFORE working with pyrophoric reagents, users must:

1. Consult with your PI and confirm that approval has been received when working with highly hazardous materials.

2. Read the relevant Safety Data Sheets (SDS), technical bulletins, and guidance documents to understand and know how to mitigate the hazards. The SDS must be reviewed before using an unfamiliar chemical and periodically as a reminder.
3. Prepare a written Standard Operating Procedure (SOP) identifying the safety precautions specific to the operations.
  - Consider performing a “dry run” to identify and resolve possible hazards before conducting the actual procedure.
  - Users of pyrophoric materials must be trained in proper lab technique and be able to demonstrate proficiency.
  - Use less toxic or less hazardous substances in your experiment and minimize the amount of hazardous waste generated.
4. Must obtain lab specific training and guidance from your PI or a designated member of the laboratory on the proper use of pyrophoric reagents, examples of such training include but are not limited to shadowing someone working with pyrophoric chemicals, and/or doing a trial run with a non-pyrophoric reagent.
5. Perform a hazard analysis and identify the failure modes in your experiment. Be prepared to handle accidents.
6. Know the location of eyewash/ shower, fire extinguishers, fire alarm pulls, and emergency exits.
7. Complete required EH&S safety training requirements (<http://www.uclc.uci.edu/>) and lab specific training.
8. Use the buddy system, always have an *informed* member of the laboratory nearby (i.e., someone who knows that you are working with pyrophoric reagents and is present in the same room). Do not work alone or off hours where there are few people around to help.
9. Wear the appropriate personal protective equipment.
  - Use a flame-resistant lab coat, goggles/face shield and gloves or other additional PPE as suggested by the SDS.

Use flame-resistant gloves, specifically you must use inner nomex gloves (pictured yellow below), which are flame-resistant and neoprene outer gloves (pictured green below), which are chemical resistant and provide more fire resistance than nitrile gloves. The appropriate glove PPE is shown below.



#### 10. Maintain good work practices.

- Keep combustible materials, including paper towels and Kimwipes, away from pyrophoric reagents. Never have unnecessary combustible materials or flammable solvents near your workspace when working with pyrophoric reagents.
- Minimize the quantity of pyrophoric reagents used and stored and use the smallest quantity of material practical. You must use the cannula method when transferring more than 20 ml. Do not syringe over 20 mL of a pyrophoric reagent. The cannula method is preferred for any amount greater than 15 mL.
  - Best practices for a scale greater than 20 mL: consider ordering 25 mL bottles of pyrophoric reagent and conducting the experiment on that scale. Use the cannula transfer method to transfer the entire bottle of a pyrophoric into the reaction mixture.
    - Only order bottles of pyrophoric chemicals as needed for the experiment. This decreases the amount of pyrophoric reagent being stored in the lab.
- Remove all excess and nonessential chemicals and equipment from the fume hood or glove box where pyrophoric chemicals will be used to minimize the risk of fire.
- Designate a fume hood or glove box for hazardous work.

### A. Personal Protective Equipment (PPE)

#### *Eye Protection*

- Chemical splash goggles or safety glasses that meet the ANSI Z.87.1 1989 standard must be worn whenever handling pyrophoric chemicals. Ordinary prescription eyeglasses will NOT provide adequate protection unless they also meet this standard. When there is the potential for splashes, goggles must be worn, and when appropriate, a face shield added.
- A face shield, worn over safety eyewear, is required any time there is a risk of explosion, splash hazard or a highly exothermic reaction. All manipulations of pyrophoric chemicals which pose this risk should occur in a fume hood with the sash in the lowest feasible position. Portable blast shields, clamped to the counter top, may be used if fume hood space is not available.

#### *Skin Protection*

- Gloves must be worn when handling pyrophoric chemicals. Nomex pilot gloves should be used for handling these chemicals neoprene gloves should be worn over the nomex gloves. Be sure to use adequate protection to prevent skin exposures. Sigma-Aldrich recommends the use of nitrile gloves underneath neoprene gloves.
- A lab coat made from Nomex is required for labs using pyrophoric reagents. Lab coats need to be buttoned completely and fit properly to cover as much skin as possible.
- Appropriate shoes that cover the entire foot (closed-toed, closed heel, no holes in the top) must be worn. Appropriate clothing must be worn under the lab coat: long pants, no synthetic fabrics, only wear natural fibers when working with pyrophoric chemicals.

### B. Safety Equipment

Have the proper equipment and the emergency phone number (9-1-1) readily available for any emergencies.

DO NOT use a carbon dioxide fire extinguisher or water to attempt to extinguish a pyrophoric solid fire as these types of extinguishers can actually enhance the combustion of these pyrophoric



materials. A small beaker of dry sand or soda ash (lime) in the work area is useful to extinguish any small fire that occurs at the syringe tip and to receive any last drops of reagent from the syringe. Liquid nitrogen can also be used to extinguish small fires. These techniques can be useful to provide time to get the fire extinguisher if it is not in easy reach.

### *Eyewash/ Safety Shower*

- A combination eyewash/safety shower should be within 10 seconds travel time where pyrophoric chemicals are used. Inside the laboratory is optimum. Bottle-type eyewash stations are not acceptable.

### *Fume Hood*

- Verify that your fume hood has been checked in the last 12 months. Many pyrophoric chemicals release noxious or flammable gases, and some pyrophoric materials are stored under kerosene. These materials must be handled in a laboratory hood or glove box.

### *Glove (dry) box*

- Glove boxes are an excellent device to control pyrophoric chemicals when inert or dry atmospheres are required.

### *Gas Cabinets*

- Storage of pyrophoric gases is described in the California Fire Code, Chapter 64(<https://www.citymb.info/Home/ShowDocument?id=28089>). Gas cabinets, with appropriate remote sensors and fire suppression equipment, are required.
- Gas flow, purge and exhaust systems should have redundant controls to prevent pyrophoric gas from igniting or exploding. All pyrophoric gases must have Restricted Flow Orifices (RFO) installed on the cylinder. Contact your gas supplier for assistance.
- Emergency back-up power should be provided for all electrical controls, alarms and safeguards associated with the pyrophoric gas storage and process systems.

## **V. Storage and Disposal**

### ***Storage***

- Use and store minimal amounts of pyrophoric chemicals. Order only the amount of chemical you will need for your experiment when possible.
- Do not store pyrophoric chemicals with flammable materials or in a flammable liquids storage cabinet. Containers carrying pyrophoric materials must be clearly labeled with the correct chemical name, in English, and hazard warnings.
- Store as recommended in the SDS. A nitrogen-filled desiccator or glove box, are suitable storage locations.
- If pyrophoric reagents are received in specially designed shipping storage or dispensing container, (such as the Aldrich Sure/Seal packaging system) ensure that the integrity of that container is maintained.
- Ensure that sufficient protective solvent, oil, kerosene, or inert gas remains in the container while the material is stored.
- NEVER return excess chemical to the original container. Small amounts of impurities introduced into the container may cause a fire or explosion.
- For storage of excess chemical, prepare a storage vessel in the following manner:

- Select a septum that fits snugly into the neck of the vessel
- Dry any new empty containers thoroughly
- Insert septum into neck in a way that prevents atmosphere from entering the clean dry (or reagent filled) flask.
- Insert a needle to vent the flask and quickly inject inert gas through a second needle to maintain a blanket of dry inert gas above the reactive reagent.
- Once the vessel is fully purged with inert gas, remove the vent needle then the gas line.
- For long-term storage, the septum should be secured with a copper wire (figure 1A).

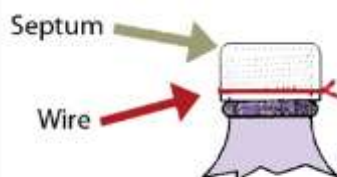

**Fig. 1A.** Septum wired to vessel

- For extra protection a second same-sized septa (sans holes) can be placed over the first (figure 1b).

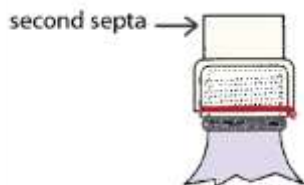

**Fig. 1B.** For long-term storage, use a second septum

- Use parafilm around the outer septa and (obviously) remove the parafilm and outer septum before accessing the reagent through the primary septum<sup>3</sup>.



### ***Disposal of Pyrophoric Reagents***

- A container with any residue of pyrophoric materials should never be left open to the atmosphere.
- Any unused or unwanted pyrophoric materials must be destroyed by transferring the materials to an appropriate reaction flask for hydrolysis and/or neutralization with adequate cooling.<sup>4</sup> Quenching these materials is a dangerous procedure always take the necessary safety precautions.
- The essentially empty container should be disposed of as hazardous waste.

### ***Disposal of Pyrophoric Contaminated Materials***

- All materials that are contaminated with pyrophoric chemicals should be disposed of as hazardous waste. Proper and complete hazardous waste labeling of containers is vital.
- Alert EH&S for any wastes contaminated with pyrophoric chemicals.
- The contaminated waste should be stored in a method to prevent the pyrophoric material from coming into contact with air and moisture. The bottle should not be left overnight in the open laboratory but must be properly contained to prevent fires.

## Important Steps to Follow

Pyrophoric reagents can be handled and stored safely as long as all exposure to atmospheric oxygen and moisture is avoided. Finely divided solids must be transferred under an inert atmosphere in a glove box. Liquids may be safely transferred without the use of a glove box by employing techniques and equipment discussed in the Aldrich Technical Information Bulletin AL-134 ([https://www.sigmaaldrich.com/content/dam/sigmaaldrich/docs/Aldrich/Bulletin/al\\_techbull\\_al134.pdf](https://www.sigmaaldrich.com/content/dam/sigmaaldrich/docs/Aldrich/Bulletin/al_techbull_al134.pdf)) and Aldrich Technical Information Bulletin AL-195 ([https://www.sigmaaldrich.com/content/dam/sigmaaldrich/docs/Aldrich/Bulletin/al\\_techbull\\_\\_al195.pdf](https://www.sigmaaldrich.com/content/dam/sigmaaldrich/docs/Aldrich/Bulletin/al_techbull__al195.pdf)). Pyrophoric gases should be handled in compliance with the California Fire Code, Chapter 64 (<https://www.citymb.info/Home/ShowDocument?id=28089>).

### Handling Pyrophoric Liquids

- Users should read and understand the Aldrich Technical Information Bulletin No. AL-134 ([https://www.sigmaaldrich.com/content/dam/sigmaaldrich/docs/Aldrich/Bulletin/al\\_techbull\\_al134.pdf](https://www.sigmaaldrich.com/content/dam/sigmaaldrich/docs/Aldrich/Bulletin/al_techbull_al134.pdf)). The PI should also have in place laboratory-specific handling, storage, and disposal standard operating procedures. The standard operating procedures should be included in the lab Chemical Hygiene Plan.
- By using proper syringe techniques, these reagents can be handled safely in the laboratory. The Aldrich Sure/Seal™ Packaging System provides a convenient method for storing and dispensing air-sensitive reagents.
- The reagent can be dispensed using a syringe or double-tipped needle (16, 18 or 20 gauge) inserted through the hole in the metal cap, as shown in fig. 2 below. It is recommended that the plastic cap be replaced after each use and in particular for long-term storage.
- For extended storage of unused reagents, use the solid plastic cap, or equip the bottle with an Oxford Sure/Seal valve cap, or transfer the reagent to a suitable storage vessel, as described above.

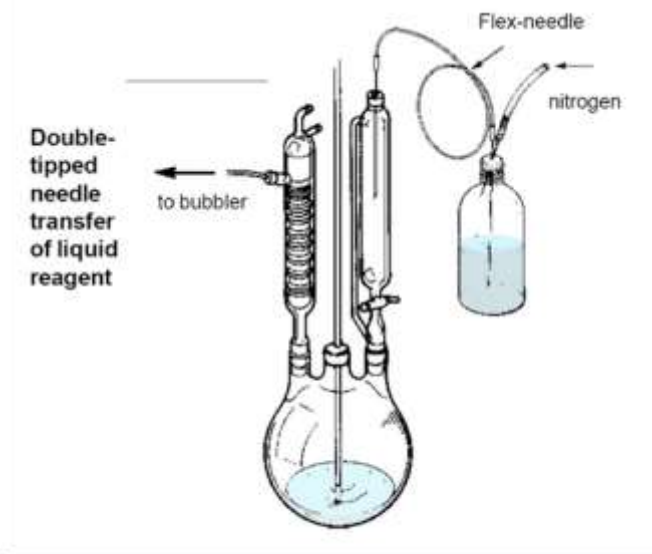

Fig. 2 Double-tipped needle transfer of liquid reagent

## Emergency Procedures

### *Spill*

- Powdered lime should be used to completely smother and cover any spill that occurs.
- DO NOT use water to attempt to extinguish a pyrophoric material fire as it can actually enhance the combustion of some pyrophoric materials, e.g., metal compounds.
- Do not use combustible materials (paper towels) to clean up a spill, as these may increase the risk of igniting the pyrophoric compound. Soda ash (powdered lime) or dry sand should be used to completely smother and cover any small spill that occurs. Liquid nitrogen can also be used to smother/cover a small spill or extinguish a small fire.
- A container of powdered lime, dry sand, or liquid nitrogen should be kept within arm's length when working with a pyrophoric material.
- If anyone is exposed, or on fire, use the safety shower to wash body with copious amounts of water.
- The recommended fire extinguisher is a standard dry powder (ABC) type. Class D extinguishers are recommended for combustible solid metal fires (e.g, sodium, lithium aluminum hydride), but not for organolithium reagents.
- Call 9-1-1 for emergency assistance
- If an incident occurs contact EH&S, 4-6200, as soon as possible.
- If there is a fire and a fire extinguisher is used contact EH&S, 4-6200, as soon as possible to ensure that the fire extinguisher is refilled in a timely manner.

Excerpt from the Sigma-Aldrich Technical Bulletins AL-134, AL-164, and AL-195 at: <https://www.sigmaaldrich.com/chemistry/chemical-synthesis/learning-center/technical-bulletins.html>.

### The Aldrich Sure/Seal™ Packaging System

The Sure/Seal packaging system (Fig. 1A) provides a convenient method for storing and dispensing air-sensitive reagents. The reagent can be dispensed using a syringe or double-tipped needle (16, 18 or 20 gauge) inserted through the hole in the metal cap. When inserting a needle through a septum, a layer of silicone or hydrocarbon grease on the septum will help. Upon withdrawal of the needle, the small hole that remains in the PTFE liner will not cause the reagent to deteriorate under normal circumstances. However, it is recommended that the plastic cap be replaced after each use and in particular for long-term storage.

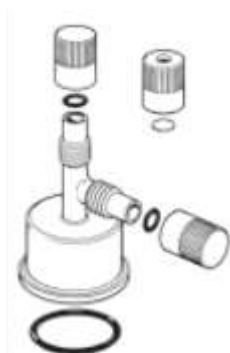

Fig. 1B. Sure/Seal septum-inlet transfer adapter

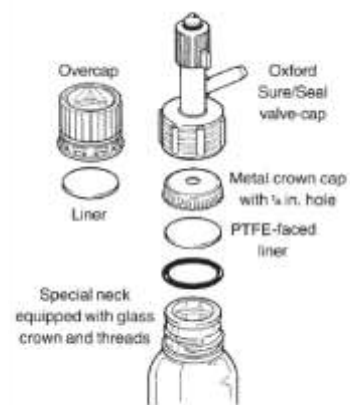

Fig. 1A Sure/Seal components

For extended storage of unused reagents, use the solid plastic cap, or equip the bottle with an Oxford Sure/Seal valve cap, or transfer the reagent to a suitable storage vessel.

The Sure/Seal septum-inlet transfer adapter (Fig. 1B) can be used when repeated dispensing is necessary. The adapter protects the contents of the bottles from air and moisture.

### Transferring Pyrophoric Reagents with Syringe

- In a fume hood or glove box, clamp the reagent bottle to prevent it from moving
- Clamp/secure the receiving vessel too.
- After flushing the syringe with inert gas, depress the plunger and insert the syringe into the Sure/Seal bottle with the tip of the needle below the level of the liquid
- Secure the syringe so if the plunger blows out of the body it, and the contents will not impact anyone (aim it toward the back of the containment)
- Insert a needle from an inert gas source carefully keeping the tip of the needle above the level of the liquid

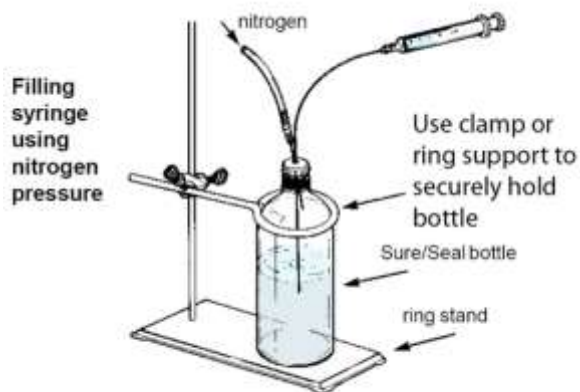
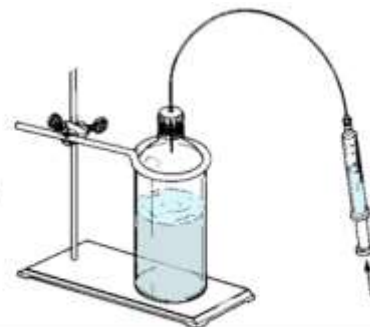

Fig. 2A. Filling syringe using nitrogen pressure

- Gently open the inert gas flow control valve to slowly add nitrogen gas into the Sure/Seal bottle.
- This will allow the liquid to slowly fill the syringe (up to 100mL) as shown in **Fig. 2B**. Pulling the plunger causes gas bubbles.
- Let nitrogen pressure push the plunger to reduce bubbles. Excess reagent and entrained bubbles are then forced back into the reagent bottle as shown in **Fig. 2B**.
- The desired volume of reagent in the syringe is quickly transferred to the reaction apparatus by puncturing a rubber septum as illustrated in **Fig. 2C**.

Removing gas bubbles and returning excess reagent to the Sure/Seal bottle



**Fig. 2B.** Removing gas bubbles and returning excess reagent to the Sure/Seal bottle

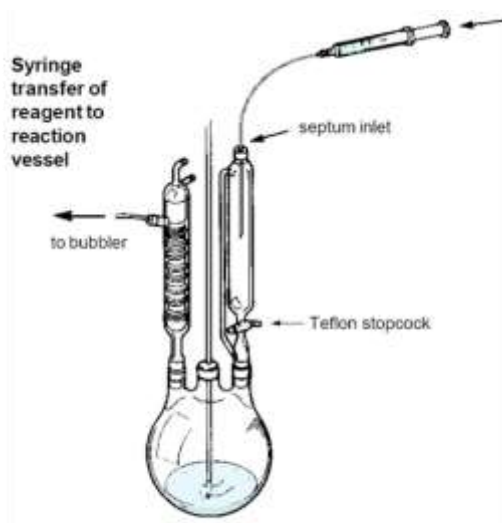

**Fig. 2C** Syringe transfer of reagent to reaction vessel

### ***Transferring Pyrophoric Reagents with a Double-Tipped Needle (Cannula)***

- The double-tipped needle technique is recommended when transferring 50 mL or more.
- Pressurize the Sure/Seal bottle with nitrogen and then insert the double-tipped needle through the septum into the headspace above the reagent. Nitrogen will pass through the needle. Insert the other end through the septum at the calibrated addition funnel on the reaction apparatus. Push the needle into the liquid in the Sure/Seal reagent bottle and transfer the desired volume. Then withdraw the needle to above the liquid level. Allow nitrogen to flush the needle. Remove the needle first from the reaction apparatus and then from the reagent bottle. (**Fig. 3A**)
- For an exact measured transfer, convey from the Sure/Seal bottle to a dry nitrogen flushed graduated cylinder fitted with a double-inlet adapter (**Fig. 3B**). Transfer the desired quantity and then remove the needle from the Sure/Seal bottle and insert it through the septum on the

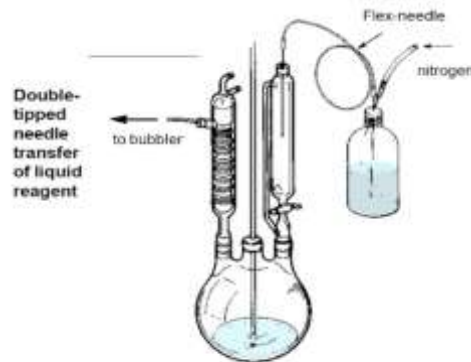

**Fig. 3A.** Double-tipped needle transfer of liquid reagent

reaction apparatus. Apply nitrogen pressure as before and the measured quantity of reagent is added to the reaction flask.

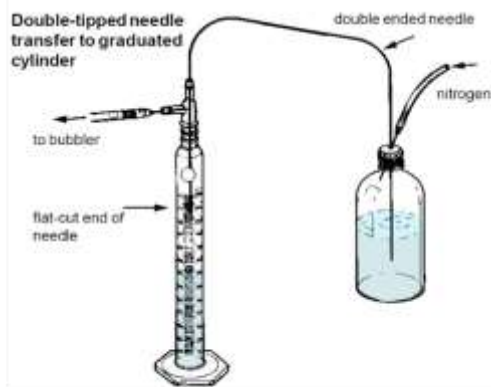

Fig. 3B. Double-tipped needle transfer to graduated cylinder

- To control flow rate, fit a Luer lock syringe valve between two long needles as shown in (Fig. 3C).

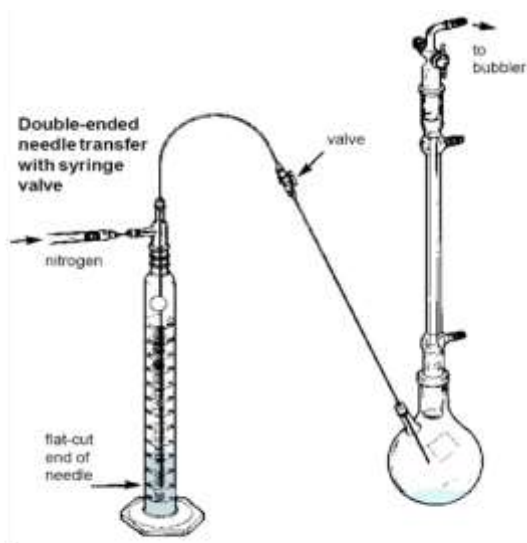

Fig. 3C. Double-ended needle transfer with syringe valve

---

## References:

1. Created from a variety of resources, principally the Sigma-Aldrich Technical Bulletins AL-134, AL-164, and AL-195 at: <https://www.sigmaaldrich.com/chemistry/chemical-synthesis/learning-center/technical-bulletins.html>.
2. Private communication to Rebecca Lally (rrlally@uci.edu) at UC Irvine in January 2009
3. Images and advice from Sigma-Aldrich Technical Bulletins
4. Destruction of Hazardous Chemicals in the Laboratory, George Lunn, Eric B. Sansone, Wiley-Interscience; 2nd edition (March 1994), ISBN: 047157399X

## Additional References:

Leonard J., B. Lygo, and G. Procter, Advanced practical organic chemistry. London: Blackie ; New York : Chapman and Hall, 1995, pages 76-98.

Prudent Practices in the Laboratory: Handling and Disposal of Chemicals, National Research Council Publisher: National Academies Press; 1 edition (January 10, 2000), ISBN: 0309052297

We wish to acknowledge the following sources: Brandeis University, Standard Operating Procedure for Pyrophoric Chemicals; University of Nebraska, Lincoln, Pyrophoric Chemicals Standard Operating Procedure; University of Pittsburgh Safety Manual, Flammable and Pyrophoric Gas; Rochester University, SOP for Pyrophoric Chemicals.

Personal communication with (and grateful acknowledgement to) Dr. Russell Vernon, Environmental Health and Safety, UC, Riverside; Dr. Joseph Pickel, Center for Nanophase Materials Sciences, Oak Ridge National Laboratory; Dr. Neal Langerman, Principal, Advanced Chemical Safety, Inc.; Dr. Frank Osterloh, Professor of Chemistry, UC Davis.

Grateful acknowledgement to Russell Vernon (russell.vernon@ucr.edu), Debbie Decker, (dmdecker@ucdavis.edu) and the UC Lab Safety Workgroup.

*These safety training resources, prepared solely for the use of the Regents of the University of California, were provided by a variety of sources. It is your responsibility to customize the information to match your specific operations. Neither the University of California nor any of its employees, makes any warranty, express or implied, or assumes any legal liability or responsibility for the accuracy, completeness, or usefulness of any information, or represents that its use would not infringe privately owned rights. Reference herein to any specific commercial product, process, or service by trade name, trademark, manufacturer, or otherwise, does not necessarily constitute or imply its endorsement, recommendation, or favoring by the University of California. The views and opinions of authors expressed herein do not necessarily state or reflect those of the University of California, and shall not be used for advertising or product endorsement purposes.*

View online at EH&S website: [Pyrophoric Reagent \(SOP\)](#) and [Pyrophoric Safety \(Video\)](#)



## Appendix H: Segregation of Incompatible Chemicals

Table M.1 contains a list of incompatible chemicals. The following chemicals, listed in the left column, should not be used with chemicals listed in the right column, except under specially controlled conditions. Chemicals in the left column should not be stored in the immediate area with chemicals in the right column. Incompatible chemicals should always be handled, stored or packed so that they cannot accidentally come into contact with one another. This list is representative of chemical incompatibilities and is not complete, nor are all incompatibilities shown. Always consult the SDS of any specific chemical to determine the incompatible chemicals. [Section 10 of an SDS, stability and reactivity, lists incompatible materials]

**Table M.1 – Incompatible Chemicals**

Chemical	Keep Out of Contact with:
Alkaline metals, such as powdered aluminum, magnesium, sodium, potassium, etc.	Carbon tetrachloride or other chlorinated hydrocarbons, carbon dioxide and water
Acetic Acid	Chromic acid, nitric acid, hydroxyl compounds, ethylene glycol, perchloric acid, peroxides and permanganates
Acetylene	Chlorine, bromine, copper, fluorine, silver and mercury
Ammonia	Mercury, chlorine, calcium hypochlorite, iodine, bromine and hydrofluoric acid
Ammonium nitrate	Acids, metal powders, flammable liquids, chlorates, nitrites, sulfur, finely divided organic or combustible materials
Carbon, activated	Calcium hypochlorite
Copper	Acetylene and hydrogen peroxide
Chromic acid	Acetic acid, naphthalene, camphor, glycerin, turpentine, alcohol and flammable liquids
Chlorine	Ammonia, acetylene, butadiene, butane, methane, propane, hydrogen, sodium carbide, turpentine, benzene and finely divided metals
Cyanides	Acids - organic or inorganic
Hydrogen peroxide	Copper, chromium, iron, most metals, alcohols, acetone, organic materials, aniline, nitromethane, flammable liquids and combustible materials
Hydrogen sulfide	Fuming nitric acid and oxidizing gases
Hydrocarbons (butane, propane, benzene, gasoline, turpentine etc.)	Fluorine, chlorine, bromine, chromic acid and sodium peroxide
Iodine	Acetylene, ammonia and hydrogen
Nitric acid	Acetic acid, aniline, chromic acid, hydrocyanic acid, hydrogen sulfide, flammable liquids, flammable gases, copper, brass and any heavy metals
Perchloric acid	Acetic anhydride, bismuth and its alloys, alcohol, paper, wood, ether, oils and grease
Phosphorous	Oxidizing agents, oxygen, strong bases
Potassium chlorate	Sulfuric and other acids

Potassium permanganate	Glycerin, ethylene glycol, benzaldehyde and sulfuric acid
Sodium	Carbon tetrachloride, carbon dioxide and water
Sodium nitrite	Ammonium nitrate and other ammonium salts
Sodium peroxide	Ethyl or methyl alcohol, glacial acetic acid, acetic anhydride, benzaldehyde, carbon disulfide, glycerin, ethylene glycol, ethyl acetate, methyl acetate and furfural
Sulfides, inorganic	Acids Sulfuric acid Potassium chlorate, potassium perchlorate and potassium permanganate

## Special Segregation of Incompatible Chemicals

In addition to the segregation noted in Table M.1, dangerously incompatible substances, even in small quantities, should not be stored next to each other on shelves or in such a position that accidental rupture of containers may allow mixing. Table M.2 contains examples of dangerously incompatible substances. Table M.3 contains examples of incompatible oxidizing agents and reducing agents. These tables are not complete, nor are all incompatibilities shown. Always consult the SDS of any specific chemical to determine the incompatible chemicals. [Section 10]

**Table M.2 – Dangerously Incompatible Substances**

Chemical	Keep out of contact with:
Chlorine	Acetylene
Chromic acid	Ethyl alcohol
Oxygen (compressed, liquefied)	Propane and hydrogen
Sodium	Chloroform and aqueous solutions
Nitrocellulose (wet, dry)	Phosphorous
Potassium permanganate	Sulfuric acid
Perchloric acid	Acetic acid
Sodium chlorate	Sulfur in bulk

**Table M.3 – Incompatible Oxidizing Agents and Reducing Agents**

Oxidizing Agents	Reducing Agents
Chlorates	Ammonia
Chromates	Carbon
Dichromates	Metals
Chromium trioxide	Metal hydrides
Halogens	Nitrates
Halogenating agents	Organic Compounds
Hydrogen peroxide	Phosphorus
Nitric acid	Silicon
Nitrates	Sulfur
Perchlorates	
Peroxides	
Permanganates	
Persulfates	

# APPENDIX I: Spill Clean-up Procedures

Laboratory personnel can clean up small spills if trained and competent to do so. Small spills include chemical spills that are up to 1 liter in size and of limited toxicity, flammability and volatility, and mercury spills from broken thermometers (about 1.5 grams). If respiratory protection is needed for spill cleanup, the spill is too large to be handled by laboratory personnel – dial **911 or EH&S, 4-6200**. Commercial chemical and mercury spill kits are available, which include protective equipment such as goggles and gloves, neutralizing and absorbing materials, bags, and scoops. You can also make your own spill kits to include the materials described below.

## Chemical Spills:

- Sodium Bicarbonate
- Citric Acid
- Vermiculite or other diking material
- pH paper
- 1 pair neoprene or nitrile gloves
- 1 pair goggles
- 1 scoop
- Spill pillows, sorbent pads
- Disposable shoe covers (plastic bags may work)

## Mercury Spills:

- Disposable gloves
- Disposable shoe covers (plastic bags will work)
- Index card or rubber squeegee
- Disposable syringe or a vacuum trap flask fitted with tubing or Pasteur pipette
- Inactivating solutions and/or powders
- Mercury sponge

## Weak Inorganic Acid or Base Spill Cleanup Procedure

1. Wear gloves, goggles, laboratory coat and shoe covers.
2. To clean-up a spill of weak inorganic acid or base, neutralize the spilled liquid to pH 5 to 8 using a **Neutralizing Agent** such as:
  - Sodium bicarbonate
  - Soda ash
  - Sodium bisulfate
  - Citric acid
3. Absorb the neutralized liquid with an **Absorbent** such as:
  - Sorbent pads
  - Diatomaceous earth
  - Dry sand
  - Sponges
  - Paper towels
  - Vermiculite

Rinse the absorbent pads or sponges in a sink with water if chemicals involved do not include any other high hazard substances like acutely toxicants or carcinogens. Scoop or place the other absorbent materials into a clear plastic bag. Double bag and tag the bag with a chemical waste label. Fill out the “Chemical Waste Collection” form to request a pickup via the internet at <http://www.ehs.uci.edu/programs/enviro/>.

## **Solvent Spill Clean Up Procedure**

1. Absorb the spill with a non-reactive material such as:
  - Vermiculite
  - Dry sand
  - Paper towels
  - Sponges
2. Package as described above. Do not rinse or dispose of any chemicals down the sink or into any drain.

## **Broken Mercury Thermometer Clean Up Procedure**

1. Clean up the spill immediately after it has occurred.
2. Prevent the spread of the spilled mercury. Do not allow people to walk through spill area.
3. Wear disposable gloves and shoe covers or place plastic bags over your shoes during the clean-up.
4. Push the mercury droplets together into a bead using an index card or rubber squeegee.
5. Aspirate the beaded mercury into a disposable syringe, or use a disposable Pasteur Pipette attached with tubing to a vacuum flask to aspirate the mercury into the flask. The flask should contain water. Always have a second vacuum flask between the mercury flask and the house vacuum.
6. Chemically inactivate any residual mercury. There are several methods to inactivate the residual mercury including:
  - Use a commercial inactivating powder following its directions for use
  - Sprinkle zinc powder over the spill area. Then moisten the zinc with a 5 to 10 percent sulfuric acid solution until a paste is formed. Scour the contaminated surface and allow the paste to dry. Sweep up the dried paste
  - Wash the contaminated area with a detergent solution. Rinse and then swab the area with a calcium polysulfide solution containing two to four tablespoons of calcium polysulfide per gallon of water

Place the collected mercury and materials used in the clean-up into a clear plastic bag. Double bag and label the waste. Fill out the "Chemical Waste Collection" form to request a pickup via the internet at <http://www.ehs.uci.edu/programs/enviro/>.

**If a large spill occurs, call 911 from a campus phone or from an off-campus or cell phone or EH&S, 4-6200.**

## Appendix J: Glossary

**ACGIH** - The American Conference of Governmental Industrial Hygienists is a voluntary membership organization of professional industrial hygiene personnel in governmental or educational institutions. The ACGIH develops and publishes recommended occupational exposure limits each year called Threshold Limit Values (TLVs) for hundreds of chemicals, physical agents, and biological exposure indices.

**ACTION LEVEL** - A concentration designated in Title 8, California Code of Regulations (29 CFR part 1910) for a specific substance, calculated as an eight (8)-hour time weighted average, which initiates certain required activities such as exposure monitoring and medical surveillance.

**ACUTE EFFECT** - Adverse effect on a human or animal which has severe symptoms developing rapidly and coming quickly to crisis.

**AEROSOL** - Liquid droplets or solid particles dispersed in air that are of fine enough size (less than 100 micrometers) to remain dispersed for a period of time.

**ALLERGY** - An abnormal response of a hypersensitive person to chemical and physical stimuli. Allergic manifestations of major importance (occurs in about 10 percent of the population).

**ASPHYXIANT** - A chemical (gas or vapor) that can cause death or unconsciousness by suffocation. Simple asphyxiants, such as nitrogen, either use up or displace oxygen in the air. They become especially dangerous in confined or enclosed spaces. Chemical asphyxiants, such as carbon monoxide and hydrogen sulfide, interfere with the body's ability to absorb or transport oxygen to the tissues.

**"C" OR CEILING** - A description usually seen in connection with a published exposure limit. It refers to the concentration that should not be exceeded, even for an instant. It may be written as TLV-C or Threshold Limit Value - Ceiling. (See also Threshold Limit Value).

**CARCINOGEN** - A cancer-producing substance or physical agent in animals or humans. A chemical is considered a carcinogen or potential carcinogen if it is so identified in any of the following:

- National Toxicology Program, "Annual Report of Carcinogens" (latest edition)
- International Agency for Research on Cancer, "Monographs" (latest edition)
- OSHA, 29 CFR 1910, Subpart Z, Toxic and Hazardous Substances

**CHEMICAL HYGIENE OFFICER** - An employee who is designated by the employer and who is qualified by training or experience to provide technical guidance in the development and implementation of the provisions of the Chemical Hygiene Plan.

**CHEMICAL HYGIENE PLAN** - A written program developed and implemented by the employer which sets forth procedures, equipment, personal protective equipment, and work practices that (1) are capable of protecting employees from the health hazards presented by hazardous chemicals used in that particular workplace and (2) meets the requirements of OSHA regulation 29 CFR 1910.1450.

**CHRONIC EFFECT** - an adverse effect on a human or animal body, with symptoms which develop slowly over a long period of time or which recur frequently.

**COMBUSTIBLE LIQUID** - Any liquid having a flashpoint at or above 100°F (37.8°C) but below 200°F (93.3°C) except any mixture having components with flashpoints of 200°F or higher, the total volume of which make up 99% or more of the total volume of the mixture.

**COMPRESSED GAS** - A gas or mixture of gases having, in a container, an absolute pressure exceeding 40 psi at 70°F (21.1°C), or; a gas or mixture of gases having, in a container, an absolute pressure exceeding 104 psi at 130°F (54.4°C) regardless of the pressure at 70°F (21.1°C), or; a liquid having a vapor pressure exceeding 40 psi at 100°F (37.8°C) as determined by ASTM D-323-72.

**CORROSIVE** - A substance that, according to the Department of Transportation (DOT), causes visible destruction or permanent changes in human skin tissue at the site of contact or is highly corrosive to steel.

**DERMATOSIS** - cutaneous abnormality, thus encompassing dermatitis (inflammable of the skin from any cause), folliculitis, acne, pigmentary changes, nodes, and tumors.

**DESIGNATED AREA** - An area which has been established and posted with signage for work involving hazards (e.g., "select carcinogens," reproductive toxins, or substances which have a high degree of acute toxicity). A designated area may be the entire laboratory, an area of a laboratory, or a device such as a laboratory hood.

**DYSPNEA** - shortness of breath, difficult or labored breathing.

**EMERGENCY** - Any potential occurrence, such as, but not limited to, equipment failure, rupture of containers, or failure of control equipment which could result in an uncontrolled release of a hazardous chemical into the workplace.

**EXPLOSIVE** - A chemical that causes a sudden, almost instantaneous release of pressure, gas, and heat when subjected to a sudden shock, pressure, or high temperature.

**FLAMMABLE** - A chemical that falls into one of the following categories:

1. Flammable aerosol - an aerosol that, when tested by the method described in 16 CFR 1500.45, yields a flame projection exceeding 18 inches at full valve opening, or a flashback (a flame extending back to the valve) at any degree of valve opening;
2. Flammable gas - a gas that, at ambient temperature and pressure, forms a flammable mixture with air at a concentration of 13% by volume or less; or a gas that, at ambient temperature and pressure, forms a range of flammable mixtures with air wider than 12% by volume, regardless of the lower limit. (GHS definition: A gas having a flammable range with air at 20°C and a standard pressure of 101.3kPa;
3. Flammable liquid - any liquid having a flashpoint below 200°F (93°C); or
4. Flammable solid - a solid, other than a blasting agent or explosive as defined in 1910.109(a), that is liable to cause fire through friction, absorption of moisture, spontaneous chemical change, or retained heat from manufacturing or processing, or which can be ignited readily and, when ignited, burns so vigorously and persistently as to create a serious hazard. A chemical shall be considered to be a flammable solid if, when tested by the method described in 16 CFR 1500.44, it ignites and burns with a self-sustained flame at a greater than one-tenth of an inch per second along its major axis.

**FLASHPOINT** - The minimum temperature at which a liquid gives off a vapor in sufficient concentration to ignite in the presence of an ignition source or when tested as follows:

1. Tagliabue Closed Tester (See American National Standard Method of Test for Flashpoint by Tag Closed Tester, Z11.24-1979 (ASTM D-56-79) for liquids with a viscosity of less than 45 Saybolt Universal Seconds (SUS) at 100oF (37.8°C) or that contain suspended solids and do not have a tendency to form a surface film under test;
2. Pensky-Martens Closed Tester (See American National Standard Method of Test for Flashpoint by Pensky-Martens Closed Tester, Z11.7-1979 (ASTM D-73-79) for liquids with a viscosity equal to or greater than 45 SUS at 100oF (37.8°C), or that contain suspended solids, or that have a tendency to form a surface film under test; or,
3. Setaflash Closed Tester (See American National Standard Method of Test for Flashpoint of Setaflash Closed Tester (ASTM D-3278-78)). Organic peroxides, which undergo auto accelerating thermal decomposition, are excluded from any flashpoint determination methods specified above.

**GENERAL VENTILATION** - Also known as general exhaust ventilation, this is a system of ventilation consisting of either natural or mechanically induced fresh air movements to mix with and dilute contaminants in the workroom air. This is not the recommended type of ventilation to control contaminants that are highly toxic, when there may be corrosion problems from the contaminant, when the worker is close to where the contaminant is being generated, and where fire or explosion hazards are generated close to sources of ignition. (See Local Exhaust Ventilation)

**HAZARD ASSESSMENT** - A formal procedure undertaken by the supervisor in which occupational hazards for all employees are described per procedure or task, and by affected body part(s) or organ(s), and which is documented and posted in the workplace with all personal protective equipment requirements.

**HAZARD WARNING** - Any words, pictures, symbols or combination thereof appearing on a label or other appropriate form of warning which convey the hazards of the chemical(s) in the container(s).

**HAZARDOUS CHEMICAL** a chemical that is classified as a health hazard or simple asphyxiant in accordance with the Hazard Communication Standard (1910.1200). A chemical for which there is statistically significant evidence based on at least one study conducted in accordance with established scientific principles that acute or chronic health effects may occur in exposed employees. The term "health hazard" includes chemicals which are carcinogens, toxic or highly toxic agents, reproductive toxins, irritants, corrosives, sensitizers, hepatotoxins, nephrotoxins, neurotoxins, agents which act on the hematopoietic system, aspiration hazards, and agents which damage the lungs, skin, eyes or mucous membranes. A chemical is also considered hazardous if it is listed in any of the following:

1. OSHA, 29 CFR 1910, Subpart Z, Toxic and Hazardous Substances;
2. "Threshold Limit Values for Chemical Substances and Physical Agents in the Work Environment," ACGIH (latest edition);
3. "The Registry of Toxic Effects of Chemical Substances," NIOSH (latest edition); or
4. Director's List.

**HAZARDOUS MATERIAL** - Any material which is a potential/actual physical or health hazard to humans.

**HAZARDOUS MATERIAL (Department of Transportation, DOT)** - A substance or material capable of posing an unreasonable risk to health, safety, and property when transported including, but not limited to, compressed gas, combustible liquid, corrosive material, cryogenic liquid, flammable solid, irritating material, material poisonous by inhalation, magnetic material, organic peroxide, oxidizer, poisonous material, pyrophoric liquid, radioactive material, spontaneously combustible material, and/or water-reactive material.



**HAZARDOUS WASTE** - any substance (a) that has a characteristic of a hazardous waste (e.g., ignitability, corrosivity, reactivity, or EP [Extraction Procedure] toxicity) or (b) is included in the EPA's list of hazardous wastes. Listed wastes include spend solvents and discarded commercial chemical products; the latter includes acute hazardous wastes and toxic wastes.

**HEMATOPOIETIC** - substances that decrease hemoglobin function and deprive the body tissue of oxygen, such as carbon monoxide and cyanides.

**HEPA (High Efficiency Particulate Air) FILTER** - a disposable, extended medium, dry type filter with a particle removal efficiency of no less than 99.97 percent for 0.3µm particles.

**HEPTOTOXIN** - substances that produce liver damage, such as nitrosamines and carbon tetrachloride.

**HIGHLY TOXIC** - A substance falling within any of the following categories:

1. A substance that has a median lethal dose (LD50) of 50 milligrams or less per kilogram of body weight when administered orally to albino rats weighing between 200 and 300 grams each;
2. A substance that has a median lethal dose (LD50) of 200 milligrams or less per kilogram of body weight when administered by continuous contact for 24 hours (or less if death occurs within 24 hours) with the bare skin of albino rabbits weighing between two and three kilograms each; or
3. A substance that has a median lethal concentration (LC50) in air of 200 parts per million by volume or less of gas or vapor, or 2 milligrams per liter or less of mist, fume, or dust, when administered by continuous inhalation for one hour (or less if death occurs within one hour) to albino rats weighing between 200 and 300 grams each.

**IGNITABLE** - A solid, liquid or compressed gas waste that has a flashpoint of less than 140°F. Ignitable material may be regulated by the EPA as a hazardous waste as well.

**INCOMPATIBLE** - The term applies to two substances to indicate that one material cannot be mixed with the other without the possibility of a dangerous reaction.

**INGESTION** - taking a substance in by mouth.

**INHALATION** - breathing in a substance in the form of gas, vapor, fume, mist, or dust.

**IRRITANT** - A substance which, by contact in sufficient concentration for a sufficient period of time, will cause an inflammatory response or reaction of the eye, skin, nose or respiratory system. The contact may be a single exposure or multiple exposures. Some primary irritants include chromic acid, nitric acid, sodium hydroxide, calcium chloride, amines, metallic salts, chlorinated hydrocarbons, ketones and alcohols.

**LABEL** - Any written, printed or graphic material displayed on or affixed to containers of chemicals, both hazardous and non-hazardous.

**LABORATORY TYPE HOOD** - A device located in a laboratory, enclosed on five sides with a movable sash or fixed partial enclosure on the remaining side; constructed and maintained to draw air from the laboratory and to prevent or minimize the escape of air contaminants into the laboratory; and allows chemical manipulations to be conducted in the enclosure without insertion of any portion of the employee's body other than hands and arms.

**LABORATORY SCALE** - means works with substances in which containers used for reactions, transfers, and other handling of substances are designed to be easily and safely manipulated by one person. "Laboratory scale" excludes those workplaces whose function is to produce commercial quantities of materials.

**LABORATORY USE OF HAZARDOUS CHEMICALS** - Handling or use of such chemicals in which all of the following conditions are met:

1. Chemical manipulations are carried out on a "laboratory scale";
2. Multiple chemical procedures or chemicals are used;
3. The procedures involved are not part of a production process nor in any way simulate a production process; and
4. "Protective laboratory practices and equipment" are available and in common use to minimize the potential for employee exposure to hazardous chemicals.

**LOCAL EXHAUST VENTILATION (Also known as exhaust ventilation)** – A ventilation system that captures and removes the contaminants at the point they are being produced before they escape into the workroom air. The system consists of hoods, ductwork, a fan, and possibly an air-cleaning device. Advantages of local exhaust ventilation over general ventilation include: it removes the contaminant rather than dilutes it, requires less airflow and, thus, is more economical over the long term; and the system can be used to conserve or reclaim valuable materials; however, the system must be properly designed with the correctly shaped and placed hoods, and correctly sized fans and ductwork.

**LC50** - lethal concentration that will kill 50 percent of the test animals within a specified time.

**LD50** - lethal dose required to kill 50 percent of the exposed species within a specified time.

**MEDICAL CONSULTATION** - A consultation which takes place between an employee and a licensed physician for the purpose of determining what medical examinations or procedures, if any, are appropriate in cases where a significant exposure to a hazardous chemical may have taken place.

**MIXTURE** - Any combination of two or more chemicals if the combination is not, in whole or in part, the result of a chemical reaction.

**MUTAGEN** Anything that cause permanent changes in the amount or structure of the genetic material in a living cell. Anything that can cause a change (or mutation) in the genetic material of a living cell.

**NEPHROTOXINS** - substances that cause damage to the kidneys, such as certain halogenated hydrocarbons.

**NFPA** - The National Fire Protection Association; a voluntary membership organization whose aims are to promote and improve fire protection and prevention. NFPA has published 16 volumes of codes known as the National Fire Codes. Within these codes is Standard No. 705, "Identification of the Fire Hazards of Materials". This is a system that rates the hazard of a material during a fire. These hazards are divided into health, flammability, and reactivity hazards and appear in a well-known diamond system using from zero through four to indicate severity of the hazard. Zero indicates no special hazard and four indicates severe hazard.

**NIOSH** - The National Institute for Occupational Safety and Health; a federal agency that among its various responsibilities trains occupational health and safety professionals, conducts research on health and safety concerns, and tests and certifies respirators for workplace use.

**NEUROTOXINS** - substances that produce toxic effects primarily on the nervous system, such as mercury, acrylamide, and carbon disulfide.

**ODOR THRESHOLD** - The minimum concentration of a substance at which a majority of test subjects can detect and identify the substance's characteristic odor.

**OXIDIZER** - Is a substance that gives up oxygen easily to stimulate combustion of organic material.

**OSHA** - U.S. Occupational Safety and Health Administration, within U.S. Department of Labor.

**PERMISSIBLE EXPOSURE LIMIT (PEL)** - An exposure, inhalation or dermal permissible exposure limit specified in 8 CCR 5155. PELs may be either a time-weighted average (TWA) exposure limit (8-hour), a 15-minute short-term limit (STEL), or a ceiling (C).

**PERSONAL PROTECTIVE EQUIPMENT** - Any devices or clothing worn by the worker to protect against hazards in the work environment. Examples include respirators, gloves, and chemical splash goggles.

**PHYSICAL HAZARD** a chemical that is classified as posing one of the following hazardous effects: explosive; flammable (gases, aerosols, liquids, or solids); oxidizer (liquid, solid, or gas); self-reactive; pyrophoric (gas, liquid, or solids); self-heating; organic peroxide; corrosive to metal; gas under pressure; in contact with water emits flammable gas; water-reactive; combustible (liquid or dust) or unstable.

**PYROPHORIC** - A chemical that will spontaneously ignite in the air at a temperature of 130°F (54.4°C) or below.

**REACTIVITY** - A substance's susceptibility to undergoing a chemical reaction or change that may result in dangerous side effects, such as explosion, burning, and corrosive or toxic emissions. The conditions that cause the reaction, such as heat, other chemicals, and dropping, will usually be specified as "Conditions to Avoid" when a chemical's reactivity is discussed on an SDS.

**REPRODUCTIVE TOXINS** - Chemicals that affect the reproductive capabilities including adverse effects on sexual function and fertility in adult males and females, as well as adverse effects on the development of the offspring including chromosomal damage (mutations) and effects on fetuses (tetragonogenesis).

**RESPIRATOR** - A device which is designed to protect the wearer from inhaling harmful contaminants.

**RESPIRATORY HAZARD** - A particular concentration of an airborne contaminant that, when it enters the body by way of the respiratory system or by being breathed into the lungs, results in some body function impairment.

**SAFETY DATA SHEET (SDS)** - Written or printed material concerning a hazardous chemical which is prepared in accordance with paragraph (g) of 29 CFR 1910.1200. Formerly known as a Material Safety Data Sheet (MSDS).

**SELECT CARCINOGENS** - Any substance which meets one of the following:

1. It is regulated by OSHA as a carcinogen; or

2. It is listed under the category, "known to be carcinogens," in the Annual Report on Carcinogens published by the National Toxicology Program (NTP) (latest edition);or
3. It is listed under Group 1 ("carcinogen to humans") by the International Agency for Research on Cancer Monographs (IARC)( latest editions); or
4. It is listed in either Group 2A or 2B by IARC or under the category, "reasonably anticipated to be carcinogens" by NTP.

**SENSITIZER** - A substance that may cause no reaction in a person during initial exposures, but afterwards, further exposures will cause an allergic response to the substance.

**SHORT-TERM EXPOSURE LIMIT** - Represented as STEL or TLV-STEL, this is the maximum concentration to which workers can be exposed for a short period of time (15 minutes) for only four times throughout the day with at least one hour between exposures. Also the daily TLV-TWA must not be exceeded.

**SOLVENT** - A substance, commonly water, but in industry often an organic compound, which dissolves another substance.

**THRESHOLD LIMIT VALUE (TLV)** - Airborne concentration of substances devised by the ACGIH that represents conditions under which it is believed that nearly all workers may be exposed day after day with no adverse effect. TLVs are advisory exposure guidelines, not legal standards, which are based on evidence from industrial experience, animal studies, or human studies when they exist. There are three different types of TLVs: Time-Weighted Average (TLV-TWA), Short-Term Exposure Limit (TLV-STEL), and Ceiling (TLV-C). (See also PEL).

**TOXICITY** - A relative property of a material to exert a poisonous effect on humans or animals and a description of the effect and the conditions or concentration under which the effect takes place.

**VAPOR** - The gaseous form of substances which are normally in the liquid or solid state (at normal room temperature and pressure). Vapors evaporate into the air from liquids such as solvents. Solvents with lower boiling points will evaporate faster.

**VOLATILITY** - the tendency or ability of a liquid to vaporize.

## PARTIAL LIST OF SYMPTOMS OF OVEREXPOSURE TO HAZARDOUS CHEMICALS

SDSs, labels, and reference materials describe the potential symptoms of exposure to chemicals. Below is a partial list of symptoms of overexposure to hazardous chemicals. The definition of selected symptoms are in parenthesis.

Abdominal cramps	Cyanosis (blue to purple skin color)
Alopecia (loss of hair)	Dark urine
Amenorrhea (stoppage of menstruation)	Dehydration (excessive loss of body water)
Amnesia (partial or total loss of memory)	Delirium (mental confusion)
Analgesia (loss of sensitivity to pain)	Dental erosion (gradual loss of the normally hard surface of the tooth)
Anesthesia (loss of feeling)	Depression, mental
Angina pectoris (chest pain)	Dermatitis (inflamed and reddened skin)
Anorexia (loss of appetite)	Diaphoresis (profuse perspiration)
Anosmia (loss of sense of smell)	Diarrhea
Anuria (lack of urination)	Disequilibrium (inability to maintain balance)
Anxiety (feeling of worry, nervousness, or unease)	Disordered gait (change in walking pattern)
Aphasia (inability to talk coherently)	Dizziness (sensation of spinning around and losing one's balance)
Apnea (breathing temporarily stopped)	Droping (drop saliva uncontrollably from the mouth)
Areflexia (loss of reflexes)	Drowsiness (feeling of being sleepy and lethargic; sleepiness)
Argyria (blue colored tissue from silver)	Dysarthria (difficulty in speaking clearly)
Arrhythmia (irregular heartbeat)	Dysosmia (impaired sense of smell)
Arthralgia (joint pain)	Dysphagia (difficulty in swallowing)
Asphyxia (suffocation)	Dyspnea (difficulty in breathing)
Asthenia (loss of strength or energy)	Dysuria (painful or difficult urination)
Asthma (difficulty in breathing)	Eczema (itching and burning skin)
Ataxia (inability to walk straight)	Edema (fluid retention, swelling)
Athetosis (slow writhing movements of fingers)	Emaciation (extreme low weight)
Atrophy (reduction in size or function of body)	Embolism (obstruction of a blood vessel)
Blindness (unable to see)	Emphysema (difficulty breathing)
Blurred vision (inability to see fine detail)	Epistaxis (nosebleed)
Bradycardia (slow heart beat)	Erythema (reddened skin)
Bronchitis (inflammation of the mucous membrane in the bronchial tubes)	Euphoria (exaggerated feeling of well-being)
Burn (tissue damage)	Fasciculation (muscle twitching under skin)
Cancer (abnormal tissue growth)	Fainting (lose consciousness for a short time)
Cataracts (eye becomes progressively opaque)	Fatigue (extreme tiredness)
Changes in body/breath odor	Fever (abnormally high body temperature)
Cheilitis (inflammation of the lips)	Fibrillation (rapid muscle contractions)
Chemical pneumonitis (inflammation of the lungs)	Fluorosis (darkening of the teeth)
Chills	Footdrop (dragging of the foot while walking)
Chloracne (reddish skin rash)	Frostbite (injury to body tissues caused by exposure to extreme cold)
Chorea (jerky uncontrolled movements of limbs)	Gangrene (tissue death)
Colic (abdominal pain due to intestinal gas)	Gasping (difficulty catching breath)
Collapse (fall down and become unconscious)	Gastroenteritis (inflammation of the stomach and intestine)
Coma (deep unconsciousness that lasts for a prolonged or indefinite period)	Giddiness (dizziness, silliness)
Confusion (lack of understanding; uncertainty)	Glossitis (tongue swelling)
Conjunctivitis (inflamed and reddened eyes)	Halitosis (foul-smelling breath)
Constipation (bowel movements that are infrequent or hard to pass)	Hallucination (experience involving the apparent perception of something not present)
Convulsions (sudden, violent, irregular movement of a limb or of the body)	Headache (continuous pain in the head)
Coughing (expel air from the lungs with a sudden sharp sound)	Hematuria (blood in the urine)
Coughing blood (force something, especially blood) out of the lungs or throat by coughing)	Hemiparesis (paralysis of one side of the body)

Hemorrhage (bleeding)  
 Hyperemia (congestion of blood in a body part)  
 Hyperkinesis (excess activity or motion)  
 Hyperpigmentation (excessive coloring of the skin)  
 Hyperthermia (elevated body temperature)  
 Hyperventilation (sudden rapid breathing)  
 Hypocalcemia (calcium deficiency of the blood)  
 Hypothermia (lowered body temperature)  
 Hypoxia (insufficient oxygen)  
 Icterus (tissue discoloration)  
 Impotence (loss of sexual ability)  
 Incoordination  
 Inflammation (swelling, redness)  
 Inflexibility (rigidity, inability to move)  
 Insomnia (inability to obtain normal sleep)  
 Interstitial fibrosis (scarring of the lungs)  
 Involuntary defecation  
 Involuntary urination  
 Iridocyclitis (inflammation of the iris)  
 Irritability (quality or state of being irritable)  
 Itch (uncomfortable sensation on the skin that causes a desire to scratch)  
 Jaundice (yellow discoloration of skin or eyes)  
 Keratosis (horny growths on skin)  
 Lacrimation (excessive eye tearing)  
 Lassitude (sense of weariness)  
 Lesion (injury to tissue)  
 Lethargy (sluggish feeling)  
 Lightheadedness (dizziness)  
 Lipid granuloma (inflamed lung tissue)  
 Lipid pneumonia (from aspiration of oily materials)  
 Malnutrition (lack of proper nutrition)  
 Melena (black tarry vomit or stools)  
 Menstrual changes  
 Metallic taste  
 Miosis (pupil contraction)  
 Miscarriage  
 Myotonia (temporary muscle rigidity and spasm)  
 Narcosis (stupor or uncontrolled sleeping)  
 Nasal ulceration (perforation of nasal tissue)  
 Nausea (feeling of sickness with an inclination to vomit)  
 Necrosis (localized death of tissue)  
 Neoplasm (abnormal tissue growth)  
 Nephrotoxic (poisonous to the kidney)  
 Nervousness (quality or state of being nervous)  
 Neuritis (inflammation of the nerves)  
 Nocturia (excessive urination at nighttime)  
 Numbness (state of being numb)  
 Ochronosis (dark spots on skin)  
 Oliguria (decreased urination)  
 Opisthotonos (spasms with body arched from head to heels)  
 Oxide pox (dermatitis from oxide contact)  
 Pallor (unhealthy pale appearance)  
 Palpitations (forceful heartbeat)  
 Paralysis (loss of the ability to move)  
 Paresthesias (abnormal tingling)  
 Paroxysmal (sudden recurrence of disease)  
 Perforation (opening through a tissue)  
 Pharyngitis (sore throat)  
 Phlebitis (swollen, painful vein)  
 Photophobia (inability to tolerate light)  
 Photosensitization (allergic reaction to light)  
 Phototoxicity (irritant reaction to light)  
 Pneumoconiosis (material particles in the respiratory track)  
 Prostration (marked loss of strength)  
 Proteinuria (presence of protein in the urine)  
 Ptosis (drooping of upper eyelid)  
 Pulmonary edema (fluid in the lungs)  
 Pyorrhea (swollen, bleeding gums)  
 Pyuria (pus in urine)  
 Respiratory distress  
 Rhinorrhea (excessive nasal discharge)  
 Salivation (discharge of saliva)  
 Scotoma (blind spot in field of sight)  
 Seizure (action of capturing someone or something using force)  
 Sensitization (allergic reaction)  
 Shock (depression of all bodily functions)  
 Siderosis (lung and tissue damage from iron particles)  
 Silicosis (lung condition from silica dusts)  
 Spasms (sudden involuntary muscular contraction or convulsive movement)  
 Stomatitis (swelling of the mouth lining)  
 Strabismus (lack of coordinated eye movement, crossed eyes)  
 Sweating (excessive moisture on skin)  
 Swelling (of tissues)  
 Tachycardia (abnormal rapid heartbeat)  
 Tachypnea (increased respiratory rate)  
 Tetany (intermittent muscle spasms)  
 Tick (skin twitch)  
 Tinnitus (ringing in the ears)  
 Tracheobronchitis (coughing, difficulty breathing)  
 Tremors (shaking, trembling)  
 Tumor (swelling or growth)  
 Ulceration (tissue destruction)  
 Urticaria (skin eruption)  
 Vertigo (feeling of whirling motion)  
 Vesiculation (blisters)  
 Vomiting  
 Wheezing (breathing with a whistling or rattling sound in the chest.)  
 Wrist drop (inability to extend hand at wrist)